



THE

LOST WAYS

— II —

**THE
LOST
WAYS
II**

This book is dedicated to all the pioneers
who overcame the toughest times and built one of
the greatest nations of all.

THE LOST WAYS II

**Special thanks to all the authors for making this
book possible:**

Aaron

Diane Watkins

James Walton

Arminius

Dana Mack

Julie Danes

John Paicu

Hunter Riley

**Edited and copyrighted by Claude Davis
(www.askaprepper.com)**

© 2017 Claude Davis

First Edition

(a Global Brother production)

This book is in copyright. Subject to statutory exception and to the provision of relevant collective licensing agreements, no reproduction of any part may take place without the written permission of the editor.

DISCLAIMER

This book is designed only to provide information. This information is provided and sold with the knowledge that the publisher, editor and authors do not offer any legal or other professional advice. In the case of a need for any such expertise consult with the appropriate professional. This book does not contain all information available on the subject. This book has not been created to be specific to any individual's or organizations' situation or needs. Every effort has been made to make this book as accurate as possible. However, there may be typographical and or content errors. Therefore, this book should serve only as a general guide and not as the ultimate source of subject information. The authors, editor and publisher shall have no liability or responsibility to any person or entity regarding any loss or damage incurred, or alleged to have incurred, directly or indirectly, by the information contained in this book. You hereby agree to be bound by this disclaimer or you may return this book within the guarantee time period for a full refund.

Some products described in this book do not comply with FDA, USDA or FSIS regulations or local health codes. Dehydrating meat products does not reduce

THE LOST WAYS II

the health risks associated with meat contaminated with Salmonella and/or E. coli O157H7.

The instructions provided have not been reviewed, tested, or approved by any official testing body or Government agency.

The authors and editor of this book makes no warranty of any kind, expressed or implied, regarding the safety of the final products or the methods used. The use, making or consumption of any products described in this book will be done at your own risk.

Some names and identifying details have been changed to protect the privacy of individuals.

THE LOST WAYS II

TABLE OF CONTENTS

<i>Disclaimer</i>	<i>4</i>
<i>How to Make 6 Pounds of Charcoal the Old-Fashioned Way.....</i>	<i>15</i>
<i>Guide to Making Charcoal</i>	<i>18</i>
<i>How to Make Activated Charcoal.....</i>	<i>28</i>
<i>What is activation?.....</i>	<i>29</i>
<i>Making it at home</i>	<i>30</i>
<i>What's it for?</i>	<i>39</i>
<i>How to Make a Gas Mask with Activated Charcoal</i>	<i>41</i>
<i>How to Make a Water Filter Using Activated Charcoal.....</i>	<i>54</i>
<i>The First Method.....</i>	<i>59</i>
<i>The Second Method</i>	<i>59</i>
<i>How to Make Activated Charcoal Pills for Intoxications and Stomach Aches.....</i>	<i>65</i>
<i>Tablets or capsules?</i>	<i>66</i>
<i>Preparing your charcoal.....</i>	<i>67</i>
<i>When to use them.....</i>	<i>73</i>
<i>How to Render Lard and How to Preserve Meat in It Like the Pioneers</i>	<i>76</i>
<i>How to Render Lard</i>	<i>77</i>

THE LOST WAYS II

Preserving Meat for a Year with Lard.....	82
<i>Edible Plants You Can Find in The Wild</i>	<i>84</i>
Where to Gather Wild Foods.....	85
The Universal Edibility Test	86
Acorns and the Oak Tree, Quercus and Lithocarpus ..	89
Amaranth, Amaranthus retroflexus	90
Asparagus, Asparagus officinalis.....	92
Autumn Olive, Elaeagnus umbellata	93
Beech, Fagus grandifolia	94
Balsam Fir, Abies Balsamea	96
Black Cohosh, Cimicifuga Racemosa	98
Blackberries.....	99
Black Locust, Robinia pseudoacacia,	100
Bloodroot, Sanguinaria Canadensis	102
Blueberry, Cyanococcus, American Blueberry	103
Bull Thistle, Cirsium vulgare.	104
Bunchberry, Cornus Canadensis,	106
Burdock, Arctium lappa.....	107
Cattail, Typha	109
Clover, Trifolium	110
Chicory, Cichorium intybus,.....	112
Chickweed, Stellaria media	113

THE LOST WAYS II

Chufa Sedge, <i>Cyperus esculentus</i>	115
Cleavers, <i>Galium aparine</i>	116
Crab Apples, <i>Malus</i>	118
Curled Dock, <i>Rumex crispus</i>	119
Dandelion, <i>Taraxacum officinale</i>	121
Elderberries, <i>Sambucus</i>	122
Fiddleheads, <i>Matteuccia struthiopteris</i>	124
Field Pennycress, <i>Thalspi vulgaris</i>	125
Fireweed, <i>Epilobium angustifolium</i>	127
Foxglove, <i>Digitalis Purpurea</i>	128
Garlic Grass, <i>Allium vineale</i>	129
Garlic Mustard, <i>Alliaria petiolata</i>	131
Gooseberry, <i>Ribes</i>	132
Indian Cucumber Root, <i>Medeola virginiana</i>	133
Green Seaweed, <i>Ulva Lactuca</i>	135
Hazelnuts, <i>Corylus avellane</i>	136
Hickory, <i>Carya</i>	137
Jerusalem Artichoke, <i>Helianthus tuberosus</i>	138
Japanese Knotweed, <i>Fallopia japonica</i>	139
Joe-Pye Weeds, <i>Eutrochium</i>	140
Kelp, <i>Alaria esculenta</i>	142
Kudzu, Japanese Arrowroot	143

THE LOST WAYS II

Lamb's Quarters, <i>Chenopodium</i>	144
Mayapple, <i>Podophyllum</i>	145
Mustang Grapes, <i>Vitis mustangensis</i>	147
Miners Lettuce, <i>Claytonia perfoliate</i>	148
Monkey Flower, <i>Erythranthe</i>	149
Pecans, <i>Carya illinoensis</i>	151
Persimmon, <i>Diospyros virginiana</i>	152
Pine Trees, <i>Pinus</i>	153
Pineapple Weed, <i>Matricaria discoidea</i>	155
Plantain, <i>Plantago</i>	157
Prickly Pear Cactus, <i>Opuntia compressa</i> , <i>Opuntia drummondii</i> , and <i>Opuntia vulgaxis</i>	158
<i>Prunella vulgaris</i>	160
Purslane, <i>Portulaca oleracea</i>	161
Red Mulberry, <i>Morus rubra</i>	163
Rose, <i>Rosaceae</i>	164
Seneca Snakeroot, <i>Polygala Senega</i>	165
Sheep Sorrel, <i>Rumex acetosella</i>	167
Spikenard, <i>Aralia Racemosa</i>	168
Spruce, <i>Picea</i>	170
Sunflower, <i>Helianthus Annuus</i> , Common Sunflower	171
Sweet Rocket, <i>Hesperis matronalis</i>	173

THE LOST WAYS II

Tobacco, <i>Nicotiana Tabacum</i>	174
Violets, <i>Viola Papilionacea</i>	176
Walnuts, <i>Juglans</i>	177
Watercress, <i>Nasturtium officinale</i>	179
White Mustard, <i>Sinapis alba</i>	180
Wild Black Cherry, <i>Prunus serotina</i>	182
Wild Leeks, <i>Allium tricoccum</i>	183
Wild Potato-Vine, <i>Ipomoea Pandurata</i>	184
Wild Plum, <i>Prunus americana</i>	186
Wild Yam, <i>Dioscorea Villosa</i>	187
Wintergreen, <i>Gaultheria procumbens</i>	188
Witch Hazel, <i>Hamamelis Virginiana</i>	190
Wood Sorrel, <i>Oxalis</i>	191
Yaupon, <i>Ilex vomitoria</i>	192
Yellow Birch, <i>Betula alleghaniensis</i>	193
Yellow Rocket, <i>Barbarea</i>	195
<i>How to Preserve Half a Pig for a Year Without Refrigeration</i>	197
Curing the Meat	197
Making the Curing Broth and Letting the Meat Rest	200
Ingredients:	200
Preparing the Pork's Back Fat	208

THE LOST WAYS II

Preparing the Meat for Smoking and the Process of Smoking	211
<i>How To Sharpen Your Blades like The Samurai Did</i>	217
The samurai sharpening kit:	219
Soaking your stones	220
Get a Grip	221
Follow the Given Path	221
Shitagi Togi	222
100 Strokes.....	223
Shiaji Togi	223
Polish	224
Finish.....	225
<i>How to Wax Cheese</i>	228
Ingredients	229
Melting the Wax	229
Adding the Honey (Optional).....	230
Brushing the Cheese/Dipping the Cheese	231
Essential Reminders	238
<i>How to Build a Log Cabin Like the Early Settlers of North America</i>	240
Preparing the Logs & Settling the Foundation	250
Building the walls, door & windows.....	253
Inside Flooring	254

THE LOST WAYS II

The Roof.....	257
A Case Study:	264
How I Built My Log Cabin Following the Pioneer Method Using Modern Tools	264
<i>How to Make Chuños, The Inca Survival Food</i>	<i>284</i>
Why the Incas Preserved Foods	285
Methods Used by the Inca Civilization.....	286
How To Make Chuños.....	287
Selection of potatoes	287
Freeze first	287
Place in the sun	288
Refreeze	290
Repeat in the sun	290
Let harden	292
<i>How the Pioneers Dug Their Wells to Procure Fresh Water.....</i>	<i>295</i>
Well drilling technology used by the pioneers	299
Spring-pole well	300
Treadles & teeter-totters.....	302
Steam-powered drill rigs.....	302
The walking beam	303
How to Dig and Build Your Own Well Like the Pioneers	303
<i>Deer Hunting Basics and Steps to Hide Tanning... 308</i>	
Deer Hunting Basics.....	309
What Deer Need	310

THE LOST WAYS II

When Deer Move	311
Deer Behavior in Different Seasons	313
Early Season:	313
Rut:	314
Late Season:	314
How to Set Up	315
After the Harvest/The Hide	317
Tanning Guide: Step by Step.....	318
Removing the Hide:.....	318
Removing the Flesh:.....	318
Hair or No Hair:	319
Removing the Hair:.....	320
Salting:.....	321
Cleaning the Hide:	322
Tanning:.....	322
Draining the Hide:	323
Softening the Hide:	323
Conclusion	324
<i>How to make a Native American Bow and A Bone Arrow (With Pictures)</i>	<i>326</i>
Tools:	331
Getting the Wood	332
Drying the Wood.....	333
Preparing the Wood.....	335
Giving the Bow Its Shape.....	336
Smoothing It Out	340

THE LOST WAYS II

Bow Bending.....	345
Covering the Handle with Leather for a Better Grip	349
Making a String out of Intestine.....	352
Making the Bone Arrow.....	358
Putting the Feathers on and Trying It Out.....	368
<i>How to Make Natto, The Lost Samurai Super Food</i>	
.....	374
Mineral Rich	377
Yeast Feast	378
You'll need:	378
The Process of Making Natto	378
<i>How to Make Sausages (Kielbasa) and Smoke Them</i>	
.....	387
Ingredients:	387
Getting Ready	388
Grinding the Meat and Adding the Spices	389
Trying Out the Sausage	391
Actually Making the Sausages.....	395
Smoking the Sausage	398
<i>How to Smoke Bacon in Two Different Ways.....</i>	401
Ingredients:	401
Preparing the Meat	403
Getting the Curing Mix Ready	403
Curing the Bacon	404
Option One: Smoking the Meat Inside a Smokehouse ...	406
Option Two: Smoking the Meat on a Grill	408

HOW TO MAKE 6 POUNDS OF CHARCOAL THE OLD- FASHIONED WAY

- By Claude Davis -

*“By failing to prepare, you are
preparing to fail.”*

- Benjamin Franklin

For most of us charcoal is just something you pick up at the gas station when you plan to fire up the grill. If you're an artist you might also use sticks of it for sketching. Beyond that, it isn't something we usually have a lot of use for.

If you want to smelt iron, or most other metals, charcoal is an essential part of the process. It's one of the few easily obtained fuels that can produce the high temperatures required for a long enough time to extract metal from ore. It's the fuel you need to power a forge for blacksmithing. If civilization ever falls far

THE LOST WAYS II

enough that we need to rebuild basic metallurgy from scratch, we're going to need lots of charcoal.

It has other uses too. Charcoal is excellent at soaking up contaminants, so it's valuable if you plan to build a water filtration system. Powdered clean charcoal, taken orally, can help with some stomach upsets. Add sulfur and saltpeter to finely ground charcoal and you have black powder. It's useful stuff.

Unfortunately, a post-SHTF raid on your local Exxon might not supply the charcoal you need. A lot of modern charcoal is briquettes, and they're far from pure – they're made from powdered charcoal or carbonized sawdust, bound together with clay and lime. Even lumpwood charcoal often has chemical additives, to repel dampness or make it easier to light. If you want pure charcoal the chances are you're going to have to make it yourself.

Luckily this isn't exactly a high-tech process, but it does take a bit of knowledge and skill. Charcoal is simply wood that's been heated to a very high temperature, but starved of the oxygen it needs to burn. This process removes water and various organic substances, leaving a residue that's very high in carbon. Modern industrial charcoal production involves heating wood or sawdust (and sometimes other materials, like coconut shell) in an airtight steel

THE LOST WAYS II

container called a retort. It's possible to do this yourself, but heating it to a high enough temperature for hours (or even days) will use a *lot* of fuel. Mostly for this reason your best bet is to use a more traditional technique, which uses wood as both the fuel and feedstock.

Traditional charcoal burners in the UK made charcoal by lighting a wood fire then covering it with turf and soil. This mound was called a clamp, like the earth-covered vegetable stores we've talked about before. A charcoal clamp works by starting a burn that's hot enough to char the entire pile of wood, but sealing it so little or no oxygen can get in.

Usually charcoal burners would build and cover the stack, leaving a small tunnel to a bundle of kindling at the center; then they'd push a burning torch into the tunnel, let the fire take hold, fill the tunnel with wood then seal off the outer end. A small hole at the top would be left to let smoke out, and when the color of the smoke changed from gray-green to blue – showing that the wood was dry- that would be covered too.

A commercial clamp could be huge – twenty to thirty feet in diameter, and containing tons of wood. A clamp that size would take weeks to burn and it had to be watched all the time; if the fire broke through the covering the hole had to be quickly plugged, or the

entire pile would blaze up and be reduced to ash. The temperature inside a clamp is extremely high, and if oxygen manages to get in the whole thing will erupt into flames.

Luckily, it's possible to build and burn a much smaller clamp – anything from about ten pounds of wood and up will work fine. A smaller clamp means a shorter burn time, all the way down to three or four hours for a very small one that yields a couple of pounds of charcoal. The clamp in the photos used about 25 pounds of seasoned wood and produced just over six pounds of charcoal.

Guide to Making Charcoal

To build a clamp, first collect your wood. Don't underestimate how much you'll need here: Making charcoal with a clamp isn't the most efficient process.

However much wood you put in, count on getting about half as much charcoal by volume and a fifth as much by weight. This is just the way the process works; some of the wood is used as fuel to char the rest. A bigger clamp will be more efficient, but you'll still be lucky to get two-thirds the volume you started with.

You also need to consider what kind of wood you want. Softwood is best avoided if possible. It will work,

THE LOST WAYS II

sort of, but the charcoal you end up with will burn quickly and generate less heat. Hardwood is much better. Apple and hickory are traditional favorites for grilling, but to be honest once it's been turned into charcoal any flavor from the wood is pretty much gone. What matters is to use hard, dense wood; it has more carbon in it, and will produce higher quality charcoal.

Clear a patch of level ground and, in the center of it, make a small platform of dry split sticks. On top of this build a mound of tinder – paper, dry leaves or anything else that will catch easily – then build a cone of split sticks around it. Leave a gap at one side so you can ignite it.



Now start to add larger sticks and logs. Prop these against the cone and build the stack outwards. Keep it packed as tightly as you can. With a normal fire you

THE LOST WAYS II

want small gaps to let air flow through the fuel, but there isn't going to be any airflow inside your clamp. The charring process will pass from one log to the next by radiated heat and contact, so the closer the logs are, the better. Fill in any gaps with smaller sticks to keep the mass as solid as possible.

The only exception is the tunnel you'll leave from the outside of the pile to the tinder in the middle.



Once the stack is fully built it needs to be covered. The first layer of covering should be turf. This prevents too much soil from mixing in with the charcoal during the process.

The clamp in the photos was built in a damp wooded area, and chunks of moss were used for the first layer.

THE LOST WAYS II



Then cover this with loose soil, leaving a chimney hole at the top and a space to light it through. If the soil is dry it should be damped down with water – not enough to soak it, just to keep it damp.



THE LOST WAYS II

Now the clamp is ready to light. Depending on how big it is you might be able to roll up some paper, light the end and shove it into the tinder, or you might need to make a torch as long as your tunnel. However you do it, set fire to the tinder in the middle and let it catch properly. Wait until the small sticks are well on fire and the fuel is catching. It's better to err on the side of caution here; letting an extra one or two percent of the wood burn is a lot less hassle than closing it up too early, so it goes out and you have to open it up and start again.



When you're happy the fire has a good hold in the center of the clamp, fill the tunnel with wood and close off the outside with turf and soil. At this point there should be smoke coming from the chimney and,

THE LOST WAYS II

probably, quite a few other places on the outside of the clamp.

Don't worry about the occasional wisp, but if any spots are smoking steadily block them with a handful of soil. Then let it cook for a little while.



If you've used dry, seasoned wood the chances are the smoke will already be clear and blue; if so you can close off the chimney after a few minutes.

If the clamp is built of green wood there will be a lot more smoke, and it will be greenish-gray and acrid.

Leave the chimney open until it turns blue, then seal it off with a piece of turf and a shovelful of earth.

THE LOST WAYS II



Now you have to be patient – and observant. The clamp needs to be watched constantly, because if the covering breaks open and air gets in, all your charcoal will catch fire and burn in minutes. If smoke begins to appear in a new spot, throw some more soil on. If parts of the covering sag or show cracks, add more soil. If a flame appears smother it with a piece of turf right away, then reinforce the spot with soil. Every so often sprinkle water over it, or give it a fine spray with a hose, to keep the soil damp.

Don't ever assume that because you've been watching your clamp for six hours and nothing has happened, it's safe to leave it for half an hour while you go and wash the smell of wood smoke out of your hair. It isn't.

THE LOST WAYS II

If the covering breaks and air gets in, it's going to burn fast. And if it's a windy day, and a few hundred pounds of charcoal has lit off, it's going to be generating blast furnace temperatures. You won't even be able to get near it, never mind put it out.

There will always be a few tiny wisps of smoke appearing, but eventually these will stop. When that happens you'll know about it, because of course you've been constantly watching the clamp. If they've stopped that means the burn is done; there's no wood left to char. It's (finally) time to take the clamp apart.

Before you start to break it open get some buckets of water or, better, a hose. There's still going to be a lot of heat inside and it can flare up when the oxygen hits it, destroying all your work at the last minute. Be ready to put out any flames. Having a stack of wet chunks of turf ready is a good idea.

Now start to open up one side. Shift the outer layer of soil, then pull the turf away. More likely than not the first thing you'll see is unburned wood. Relax; this doesn't mean it hasn't worked.

The covering usually pulls heat away from the outer layer of wood fast enough to prevent it charring. The larger the clamp, the smaller the percentage of unburned wood will be.

THE LOST WAYS II



Clear away the remaining wood and you should see a mass of charcoal, which might still be glowing red. Use a shovel to start moving it out of the clamp and spreading it on a patch of clear ground or a fireproof surface – concrete is good. Then, if you have a hose, spray it with a fine mist of water to cool it down. Otherwise sprinkle water from your buckets over it. If you don't cool it down it can burn, but try to avoid soaking it.

Progressively take the clamp to pieces, removing the cover from one section at a time and shoveling the charcoal out.

Finally you should have the entire clamp uncovered and dismantled, with your charcoal damped down and

THE LOST WAYS II

spread out on a fireproof surface. Now all you have to do is collect it, separate out any unburned wood and let it dry if you've accidentally soaked it.



Making charcoal isn't hard; it just needs attention to detail and a bit of time. Once you've mastered it you'll be able to make large amounts of an extremely useful substance. Charcoal is renewable – the raw material is simple wood – and being able to make it lets you create industrial essentials like a forge or blast furnace. If you're serious about being prepared for the worst a societal collapse could throw at you, this is an essential skill to have.

HOW TO MAKE ACTIVATED CHARCOAL

- By Claude Davis -

“There's no harm in hoping for the best as long as you're prepared for the worst.”

- Stephen King

Charcoal has many uses, and not long ago we looked at how valuable it can be in a SHTF scenario. Forget grilling your steaks; a reliable supply of it will let you build and run a forge or even a blast furnace. No matter how far society has fallen, being able to make charcoal gives you the foundation to start rebuilding metal-working industries.

Don't just think of charcoal as a fuel, though – it has a lot more uses than that. With a bit of preparation it's a great material for purifying chemicals, filtering water, even treating poisoning. What kind of preparation?

Basically you need to turn it from normal charcoal into *activated* charcoal.

What is activation?

Charcoal is mostly carbon. It's made from wood or other organic material that's been heated enough to burn out most of the chemicals in it, leaving the carbon behind.

This makes it very useful, because carbon reacts with a lot of chemicals. If you run dirty water through a carbon filter all the large particles will be filtered out – and the dissolved chemicals will react with the carbon, and be removed that way.

The problem is only the surface of the carbon reacts, so once the atoms on the surface have been used up it loses its effects.

One way to solve this is by increasing the surface area, so more atoms are available to react – and the best way to increase the surface area is to make the charcoal porous, so it's filled with millions of tiny holes.

Take an ounce of regular charcoal, with no cracks in it. This would make a cube about an inch on a side, and its surface area would be about six square inches. Turn that into activated charcoal powder and you have the same volume, but its surface area is now almost

900,000 square feet – more than *20 acres*. By activating charcoal you increase its chemical power by a stunning amount.

Making it at home

So you've decided that activated charcoal is useful stuff to have around; now where do you get it? You can buy it, but that isn't an option after the SHTF, so it's best to make it yourself. Luckily that isn't hard.

You already know how to make charcoal, so you have an unlimited supply of your main raw material. Now you just need a basic chemical and you can make all the activated charcoal you need.

The chemical you're looking for is calcium chloride. It's easily available and not expensive; you can get a 25-pound sack of it on eBay for less than \$15. The best idea is to spend a bit more and get food grade crystals; that will cost you about \$100 for a 50-pound sack.

You won't need that much for making activated charcoal, but it has plenty other uses. It's better than salt for deicing roads.

A solution of it sprayed on dirt tracks will keep dust down and prevent erosion. Adding some to canned vegetables will help keep them firm, or add salty flavor to pickles. It can help replace electrolytes if you're

THE LOST WAYS II

sweating a lot or have diarrhea. You can even use it to make self-heating meals, like the flameless heaters the military issue with MREs - one of its most obvious features is that when you dissolve it in water it gives off quite a lot of heat.



To make activated charcoal, start out by picking through a batch of home-made charcoal. Look for pieces that are clean and fully charred – no ash or unburned wood.

Break the charcoal up as small as you can. You can start by double-bagging it in strong paper sacks, or putting it between two sheets of baking paper, and using a rolling pin to crush it.

THE LOST WAYS II



THE LOST WAYS II

Next, mix the charcoal with an equal amount of calcium chloride by weight and grind the mixture to a powder. Use a mortar and pestle to grind it fine; for small amounts a coffee grinder will also work.

The important thing here is that it has to be as fine as you can get it, and thoroughly mixed. If there are a few small chips of calcium chloride that won't matter much, but what you really want is a uniform, fine gray powder.



Put the mixture in a glass or steel bowl. Don't use a plastic or aluminum one, because they might react chemically as you're working.

Your main priority right through the process is to avoid any chemical contamination, because that will use up

THE LOST WAYS II

some of the charcoal's absorbent capabilities before you've even finished making it.



Now add water to the powder. Don't use water straight out of the faucet, because that will have chemicals in it. Purified or distilled water will work fine; otherwise run tap water through a carbon filter.

You need to add three times as much water by weight as there is calcium chloride, so if you used four ounces of crystals add twelve ounces by weight of water.

Quickly, but thoroughly, mix the water into the powder. Watch out; the mixture will heat up quickly as soon as you mix water with it, and can cause burns.

THE LOST WAYS II



Some people will tell you that you can mix a solution of calcium chloride then add it to the powdered charcoal. This is wrong; unless you can mix them at a temperature of about 1,400°F all you'll get is wet charcoal. You need to grind the charcoal and calcium chloride together while they're dry.

Once water is added the solution will quickly heat up, and because they've been ground together (not just mixed) every particle of charcoal will have calcium chloride sticking to its surface. When it's wetted and heated up this stresses the charcoal, opening microscopic cracks and pores all over its surface – activating it.

Now you need to leave it to dry. The quickest way to do this is to get tightly woven cotton – an old bedsheet will do – and cover a large steel or glass bowl with it.

THE LOST WAYS II

First, wash the cotton in plain water to get rid of any detergents or laundry conditioner then let it dry. Top tip – don't use your best shirt for this, because it's going to be pretty difficult to shift the black stain from it when you're done.

Now pour the charcoal mix on top of the cotton. Rinse it with more pure water to flush out any calcium chlorate that's left in it, and leave it overnight or longer if necessary.

Collect the water that's dripped into the bowl – it's going to be pretty black, because there will be tiny particles of activated charcoal in it.

This will also be the finest, and best, charcoal – so collect it by straining through a coffee filter. When all the water has drained through turn the filter inside out and scrape off the charcoal.

You won't get a lot, but this is *very* high grade; you might want to store it separately and keep it for internal use.

If you need your charcoal in a hurry you can filter the water out with the cotton, collect the fine particles with the coffee filter, then spread it all on a cookie sheet and bake it dry in the oven – the hotter the better.

THE LOST WAYS II

Just make sure the cookie sheet is completely clean before you start, and doesn't have any traces of dish soap on it.



THE LOST WAYS II



Once the charcoal has completely dried, store it in an airtight jar and shake it well. It tends to cake itself into small lumps as it dries, but shaking will turn it back into powder.



What's it for?

Activated charcoal's superpower is in absorbing chemicals. It's particularly good at collecting poisons and toxins, from almost anywhere. If you need a water filter you can easily make one using activated charcoal as the filter element.

Tightly pack a small, finely woven cloth bag with it, jam it into the end of a pipe and you have an effective filter; water flowing through the pipe will be clean and pure when it comes out the other end.

If someone has swallowed poison, get them to chase it with activated charcoal – an ounce for children, two to four ounces for an adult. Bleach, aspirin, acetaminophen, opiates and many other common poisons will be rapidly absorbed by the charcoal as soon as it reaches the stomach, and that prevents it getting into the bloodstream.

It's also effective for many cases of mild food poisoning – bacteria, and the toxins they produce, get trapped in it too.

A paste of activated charcoal and any natural oil – coconut or olive are best – makes a good salve for insect bites or stings. The oil keeps it in place, and the charcoal draws the poison out of the bite. The oil's

THE LOST WAYS II

large molecules aren't easily trapped in the charcoal, so there won't be much effect on its absorbent powers.

If you tend to get gas after a meal, here's some good news: activated charcoal can reduce the symptoms. Just take half a teaspoon after eating and wash it down with a big glass of water. I can't promise that will completely eliminate the problem, but it will certainly help!

HOW TO MAKE A GAS MASK WITH ACTIVATED CHARCOAL

- By Claude Davis -

“All the children had to wear a gas mask in case of a gas attack by the Germans. They tried to make the masks like Mickey Mouse faces so the children would like them. But I didn't. They had big ears on them.” - Gerald Scarfe

In World War I, poison gas attacks took the Allies in the trenches on the Western Front by surprise. After a few unsuccessful attempts to find protection against chemical attacks, the British found a dead German soldier with his gasmask on and replicated the model. By January 1917 the British and US Army made the standard issue gas which is very similar with the one in use today: both use activated charcoal.

The sarin attack in Syria showed just how dangerous chemical weapons can be. That was a clumsy attack, possibly even an accidental release of sarin from a

THE LOST WAYS II

rebel weapons dump, but it still managed to kill more than eighty people and injure hundreds more. A major attack carried out by a competent military could be nearly as destructive as a nuclear strike.

It's not only chemical weapons you have to worry about, either. What about a major industrial accident? In December 1984, the safety systems on a storage tank at a pesticide factory in Bhopal, India, failed; the tank over pressurized and burst, releasing 32 tons of toxic gases. By next morning close to 4,000 people were dead. An EMP attack would cause hundreds of toxic chemical leaks all over the USA as safety systems were knocked out; potentially, millions could die.

When a chemical cloud drifts over you there's nowhere to hide, unless you happen to have a fully sealed military-grade shelter. The only thing that's going to save you is a gas mask. Your emergency equipment should include a properly fitted gas mask, and at least three in-date filter canisters, for every person in your home. Unfortunately, this can be expensive. You'll find plenty of ex-military gas masks on eBay, but most of them are obsolete foreign ones – and where are you going to find canisters for a Soviet or Israeli gas mask?

Even when canisters do appear they're usually old ones, and most likely they're totally ineffective. You

THE LOST WAYS II

can only rely on a canister if it's still sealed inside its foil pack and inside the expiration date printed on the foil. If you can find a reasonably modern NATO gas mask you might have more luck; these all use canisters with a standard 40mm thread, and there are a few companies that sell military spec ones.

If you can't get gas masks, and there's a chemical threat, you're going to have to make one. There are easy ways to do that. If you can get your hands on a full-face industrial anti-dust mask that's already a good start. These are commonly used by people who spray-paint or work with power tools, and they're good at blocking particles. They won't protect you from poisonous gases, but with some activated charcoal you can fix that easily enough.

Carefully open the canister. With some models, you can just lever the front plate off; others, you'll have to cut them open. Inside you'll find layers of fiber filter material. Take out all but the last layer and stand the canister flat on its base. Now cover the last layer of fiber with about a quarter of an inch of activated charcoal. Make sure it's evenly spread out and completely covers the fiber. Now put the other layers back until the canister is full – you'll probably have a piece of fiber left over. Then refit the front plate – use a hot glue gun to attach it if you had to cut the canister

THE LOST WAYS II

open. The filters will screen out any particles or droplets that get sucked into the canister, then the charcoal will absorb any toxic gases. The last layer of fiber just stops the charcoal being sucked into the mask.

That's the easy way, but what if you can't get your hands on an industrial mask? Or what if you have one but can't find spare canisters for it? If there's a risk of poison gases being released you're still going to need some sort of protection. Improvised defenses against riot gases like CS – wet bandannas and that sort of thing – won't be much help against industrial chemicals, and they are no use at all against a proper chemical weapon like phosgene or a nerve agent. You absolutely need the protection that activated charcoal, with its ability to absorb and lock up poisons, gives you.

The easiest way to create some protection is with standard disposable dust masks. On their own these will protect you against dust or paint droplets; fit two of them together with a layer of charcoal in between and they'll also filter out poisonous gas. Look for the type with a one-way exhale valve fitted; this will make it much easier to breathe. A box of ten masks can be

THE LOST WAYS II

picked up for less than \$10 if you look around.



You won't need the valve on the inner mask, so get a sharp knife and carefully cut around it. The masks will probably have a foam strip to go over your nose; remove that from the outer mask.



THE LOST WAYS II

Now get about half a cup of powdered activated charcoal and gradually mix in just enough water to form a stiff paste.



THE LOST WAYS II

Spread the paste all over the inside of the outer mask, keeping the thickness as even as you can.



Be careful not to get any on the valve unit – that can stop the valve working properly, so gas gets in. Now carefully place the inner mask inside the outer, making

THE LOST WAYS II

sure not to disturb the charcoal any more than you have to.



With a hot glue gun, seal the edges of the hole in the inner mask to the rim of the valve on the outer one.



THE LOST WAYS II

If you don't do this you'll find yourself breathing charcoal dust, which is extremely unpleasant. Now close the gap around the outside of the masks with strips of tape.



Make sure the edges are completely sealed, because if the charcoal gets out you'll lose your protection.



THE LOST WAYS II

You can use the mask right away if you have to, but it'll be easier to breathe if you can give it a couple of days to dry out.



Done? Great. Now make two or three more for each person who needs to be protected.

An improvised mask like this won't give as good airflow as a military gas mask, but using a mask with an exhale valve will help a lot. Wearing one, you should be able to breathe in a gas-contaminated environment for four to six hours, depending on how heavy the contamination is.

A warning though – it depends a lot on what gas we're dealing with. Activated charcoal isn't effective against

THE LOST WAYS II

hydrogen cyanide (HCN), for example; the gas quickly makes the charcoal ineffective. Soviet chemical artillery doctrine called for an attack with HCN to destroy gas mask filters, followed rapidly by nerve agent to do the killing.

You'll know if HCN is getting through your mask; if you feel dizzy, suffer headaches and weakness, start to become confused or find it hard to breathe, you're suffering the early effects.

If this happens close your eyes, hold your breath, and as quickly as you can take off the mask and put on a new one. The good news about HCN is it disperses quickly, so if you can survive for a few minutes you'll be fine – but you will need more than one mask to last that long.

Other chemicals will eventually overload the filter, although it can take hours; if you start to pick up a chemical smell, or feel any symptoms, change your mask.

In any case your first priority should be to get out of the contaminated area as quickly as possible. Soldiers have to hold their position even if it's been soaked in persistent nerve agents; you don't, so you can get away with lighter protective gear.

THE LOST WAYS II

Remember that many poisonous gases will also affect your eyes, so pair your improvised gas mask with goggles. Safety goggles – not safety glasses – will do, but check for ventilation slots on the surround. If they're ventilated seal the slots with tape or hot glue. It's better to have goggles that steam up a bit than goggles that let gas in.

Some chemical weapons – nerve and blister agents, for example – are delivered as liquids. This is spread as droplets, either from an aircraft spray tank or by a bursting charge in a bomb or shell.

The droplets evaporate to give off gas, but they're also harmful if they get on your skin – a single drop of nerve agent on the skin is enough to kill. If you can, stay under cover with your mask on during an attack.

In case you have to go out get some disposable rain capes. These cost a couple of dollars for a pack of five, and they'll keep liquid agents away from your skin long enough for you to get into cover.

For extra protection, use garbage bags held on with tape to cover your feet and legs. After a liquid attack discard anything that might have been contaminated; double-bag and bury it, if you can – *don't* burn it, because you might release toxic vapor.

THE LOST WAYS II

Poisonous gas – especially a chemical weapon – is nasty stuff and *extremely* dangerous. Even trained soldiers with state of the art protective gear will take casualties. Even a simple mask will give you a much better chance of survival, though. The one shown here is crude, but the British Army – probably the world’s leaders at chemical defense – used something similar during the Cold War, so troops could take their standard masks off for a while and still be reasonably well protected. With a mask like this, you have a good chance of getting through a chemical incident unharmed.

HOW TO MAKE A WATER FILTER USING ACTIVATED CHARCOAL

- By Claude Davis -

“Preparedness, when properly pursued, is a way of life, not a sudden, spectacular program.”

- Spencer W. Kimball

In almost any situation, safe drinking water is the number one priority. Without that, it doesn't matter how much food you have stockpiled and how prepared you are to defend your property. If you don't have water you're going to be dead in a week. The problem is that the infrastructure most of us get our water from is terrifyingly vulnerable to a SHTF scenario.

If your water comes from the municipal supply it comes via a treatment plant, and that plant is going to stop working as soon as its staff quit. If society breaks

THE LOST WAYS II

down the water coming out your faucets might look the same, but the chances are it's going to be untreated. If you have an artesian well you might be lucky, but then you might not. A lot of potential disasters can contaminate the groundwater the well draws from. A nuclear or chemical attack, or a bad industrial accident, will spread contamination; rain will flush that down into the aquifers. In an SHTF situation you can't rely on any water that hasn't been filtered.

In fact it's worse than that. A lot of chemical contaminants will dissolve in water, so a sand or textile filter won't get them out. What's needed is a filter that doesn't just trap particles, but captures molecules of dangerous substances. The solution is activated charcoal.

Activated charcoal can absorb hundreds of times its own weight of contamination, and the finer it's ground the more it can absorb. If you can filter your water through activated charcoal almost all chemicals will be removed from it – even the radioactive particles in fallout.

Your active charcoal filter should be one of the final stages in a multi-layer filtration process. You can just run water straight from source into a charcoal filter if you like, and it'll produce safe water, but you'll go through charcoal a lot faster than you have to. The

THE LOST WAYS II

filter will quickly get choked up with sediment and debris. It's much better to use gravel and sand to do the basic filtration, clearing out debris and large particles, then run the semi-treated water through the charcoal filter to remove toxic chemicals. Finally, because some bacteria and viruses can make it through, use UV sterilization to kill them. This is simple – just put the filtered water in clear plastic containers and leave it in the sun for a day.

You can buy activated carbon filters, and it's always a good idea to keep a stock of them, but what if the crisis goes on long enough that you run out? Or what if there's very heavy contamination and you need to change them a lot more often? That's when you need to be able to make your own.



THE LOST WAYS II

The first thing you need is a container that will hold the filter. This needs to be food grade (so it won't add any more contamination to the water) and large enough that the water's own weight will force it through the filter. The obvious, and cheap, solution is a plastic drink bottle. Water bottles are fine; soda bottles are better because they tend to be stiffer and more robust - they're built to take pressure.

What you're aiming to do is create a deep enough layer of charcoal for the water to pass through. The quantity of charcoal is important – if there isn't enough its ability to soak up contamination will quickly be used up – but the depth matters too. A ton of activated charcoal in a thin layer will be less effective than a pound of it in a deep column. Activated charcoal filters don't just trap pieces of contamination the way a cloth or sand filter does; they actually use chemical reactions to remove toxic substances at a molecular level. That means it's important to keep the water in contact with the charcoal long enough for the reactions to take place, and the easiest way to do that is by creating a deep layer.

If you're using something like a Coke bottle for your filter, there's a simple way to create a deeper layer – just turn the bottle upside down. The narrow neck will give more depth for the same amount of charcoal. At

THE LOST WAYS II

the other end you can either cut away the whole base to make it easy to pour water in, or modify it to suit your water storage system. If you run water through a sand filter then into a barrel with a tap, you can make a filter that fits onto the tap. If water goes from your sand filter into a pipe you can put the charcoal filter on the end of the pipe.

Once you have a suitable bottle you need to add the actual filter. The key here is to make sure the charcoal is properly contained. If it isn't, particles of it will be washed out of the filter and into your clean water. This won't do you any harm, but the filter will slowly lose effectiveness - plus anything you cook with the water will be kind of gritty. Because you'll be using the smallest particles of charcoal you can, whatever you use to contain it with will need to be a filter itself.



There are two ways to do this.

The First Method

Make a bag from tightly knit fabric and loosely fill it with charcoal.

Then securely close it, either by stitching the top closed or with a tightly knotted cord. Then just put the bag into the bottle through the hole you cut in the base and ram it down tightly into the neck end.

This is quick and easy, but it's not a perfect solution. It should filter the water pretty well, but there's a good chance some of it will be wicked down through the fabric without ever coming in contact with the charcoal. That means it's possible some contamination could make it through, which obviously isn't good news.

Ideally you want the charcoal to be in contact with the walls of the bottle all the way round. That way there's no way any water can get past it – every drop will have to filter its way through.

The Second Method

The first stage is to plug the neck of the bottle so water can get through, but charcoal can't. This is simple – just stuff a cotton ball into the neck, then secure it.

THE LOST WAYS II



A small piece of cloth held over the mouth of the bottle with a zip tie will do nicely.



Now you have to add the activated charcoal.

THE LOST WAYS II



Just pour it in the base of the bottle until there's at least three inches of it on top of the cotton, then tap the neck of the bottle on a hard surface to settle it down.



THE LOST WAYS II

The final stage is to secure the top of the charcoal. Otherwise, when water is poured into the filter the charcoal will be stirred up and mixed with it; the water won't be properly filtered, because it doesn't have to slowly trickle down through the full depth of charcoal.

Again, use a piece of cloth for this. Cut out a circle about an inch wider than the bottle and lay it on top of the charcoal.



Now get a half-inch-wide strip of springy plastic – you can cut this from another bottle – and curl it into a circle.

THE LOST WAYS II



Place that on top of the cloth and let it uncurl, so it traps the cloth between itself and the sides of the bottle.



THE LOST WAYS II

Before loading the charcoal into your filter, weigh it. This will give you a good idea how long the filter will last. An ounce of charcoal should be good for about 100 gallons of water that's already been through a sand filter – so if you used half a pound of charcoal, the filter will purify 800 gallons before it needs to be rebuilt or replaced. It's worth making at least two filters, and rebuilding used ones as soon as you swap them out, so you'll always have a fresh one ready to do. It's even better to make more than that and have a couple of spares handy. Of course, you can make as many as you want. You know how to make and activate your own charcoal, so the key ingredient is easily available and cheap. There's no reason for you ever to run out of safe water!



HOW TO MAKE ACTIVATED CHARCOAL PILLS FOR INTOXICATIONS AND STOMACH ACHES

- By Claude Davis -

*“Better to have, and not
need, than to need, and not
have.”*

- By Franz Kafka

Activated charcoal has many uses in a SHTF situation, but even when life is going on at a normal pace it's useful stuff to have around. You might not need to build a filter to obtain safe drinking water but there are always risks in the world that activated charcoal can help protect you from – anything from insect bites to food poisoning. If you have a supply about the house you can react to these situations quickly and effectively.

Most often, activated charcoal is swallowed to deal with wind or some kind of poisoning. You could keep a jar of it handy and dig in with a spoon when you need

some charcoal, but that's messy and unpleasant. It's much better to store it like other medicines – in a handy pill form.

Tablets or capsules?

There are two ways you can make activated charcoal pills at home. One is to form it into tablets, but this is quite complicated. Firstly, you need a binder material. This can be bought from a lot of health food suppliers, and it's pretty popular in the illegal drug trade too. Pill binder is a powder that, if it's compressed, binds to itself; mix it with your active ingredient (charcoal in this case), put it in a pill die and apply strong pressure. What comes out is a tablet.

The biggest problem is that you need to use quite a lot of binder – usually at least twice as much as the actual ingredient of the tablet. If you used this method to make charcoal pills you'd have to make 300mg tablets to get 100mg of activated charcoal in each one.

Cost is another problem. The binder itself isn't cheap – expect to pay at least \$30 for a one pound bag – and then you'll need a pill die. Simple hand-held ones start at around \$80 but these are very slow and fiddly. For each pill you need to measure out the right amount of powder, pour it into the die, knock the top punch down with a hammer and extract the tablet. Then you start all over again.

Making a small bottle of tablets will take you a couple of hours, easily. You can get automatic pill makers that will turn out a few dozen every minute, but they usually cost a couple of thousand dollars – and ordering one might put you on a DEA watch list.

A much easier solution is to make capsules. This doesn't need any specialist equipment or materials (apart from the capsules themselves), it's simple and relatively quick.

All you have to do is get your hands on a bag of empty gelatin capsules and you're good to go. These come in different sizes, but Size 0 is good for activated charcoal; it's big enough to hold a decent dose, without being too large to swallow easily. You can find them on eBay for less than \$10 per thousand.

Capsules have other advantages too. If someone is bitten or stung by an insect you can break the capsule open and use its contents externally to draw out the venom and ease the pain. This isn't possible if you've made tablets.

Preparing your charcoal

For medicinal use your best option is to buy food grade charcoal powder. Of course, that's fine as long as society – and the internet – is up and running. If the S has HTF, on the other hand, you're going to have to make your own.

THE LOST WAYS II

Never make activated charcoal from BBQ charcoal – either lump wood or briquettes. “Charcoal” briquettes usually contain little or no charcoal; they’re mostly made of coal dust held together with a clay binder, and impregnated with petrochemicals to help them light more easily. Lump wood charcoal actually is charcoal, but it’s also usually treated with chemicals and it certainly isn’t food grade.

Don’t include any treated timber when you’re making your charcoal – no painted siding or old creosoted fence posts. Natural toxins like those found in walnut will be cooked out as the wood chars, but some man-made chemicals can leave nasty residues.

When you activate the charcoal it’s important to use clean utensils and wash the final product thoroughly before drying it, to flush out any traces of calcium chloride. The chemical isn’t toxic but it is extremely salty, and if you’re trying to treat a stomach upset it won’t help.

It’s also important to grind the charcoal as fine as possible.

The smaller the particles the more effective it will be – and the less you’ll have to swallow. A mortar and pestle is the best way to get it really fine; work with small batches and grind it until it’s reduced to dust.

THE LOST WAYS II



Once the charcoal is ready, all you have to do is fill the capsules.

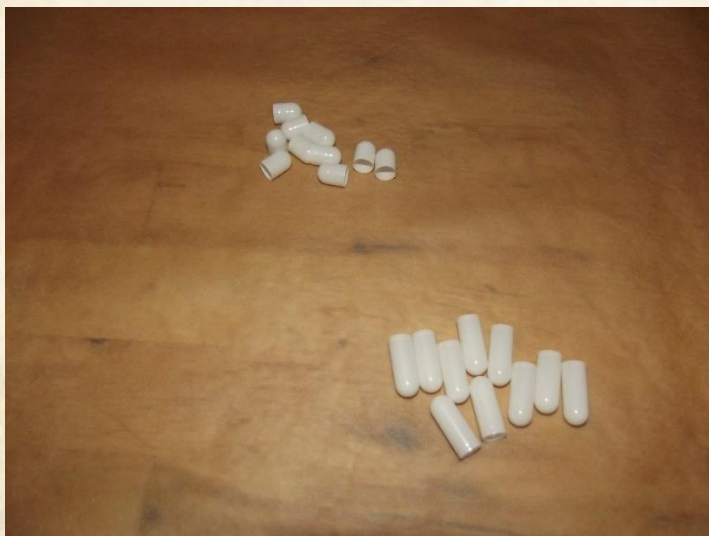

THE LOST WAYS II

Just use a folded piece of paper to scoop up some of the powder, pour it into the body of the capsule until it's full, then fit the cap and press it down until it clicks.

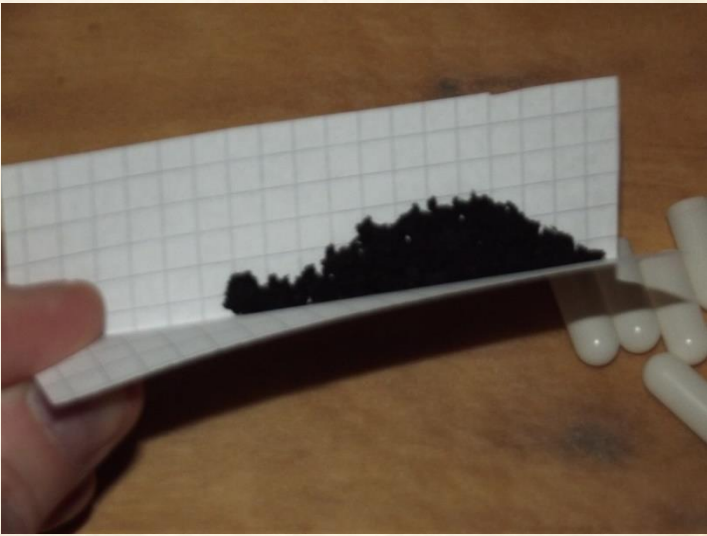
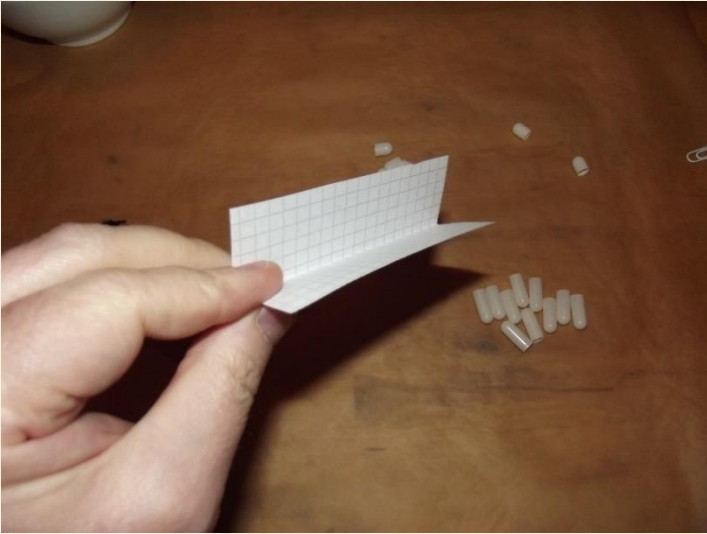

THE LOST WAYS II

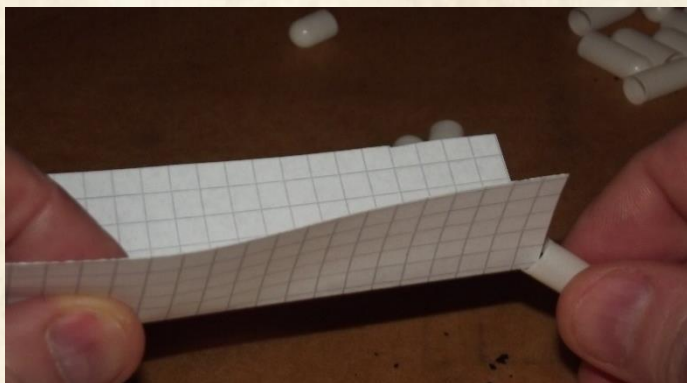

THE LOST WAYS II

Store the finished capsules in a medicine bottle to protect them from moisture.



When to use them

Some people recommend taking activated charcoal regularly as a “detox”. This is not a good idea. If you take it regularly it will absorb a lot of the nutrients from your food, leaving you with the fat and calories. Regular use can also cause constipation, which you probably want to avoid (but if you have diarrhea, activated charcoal can help with that).

A good time to break out the charcoal capsules is when you’re suffering from wind. This is an irritating condition, but one or two charcoal capsules will absorb the stomach chemicals that generate gas. Don’t forget to take the capsules with plenty of water; that will help avoid constipation.

Where your capsules will really earn their keep is when you or someone else has swallowed something poisonous – whether it’s a chemical or tainted food. Activated charcoal is so absorbent that it will soak up any poisons that are still in the stomach. It won’t be able to affect any that’s already got into the rest of the body, but by collecting the rest it reduces the total dose. That can make all the difference between mild symptoms and a serious emergency. Obviously the sooner the charcoal is swallowed the more poison it can safely capture, so it should be taken as possible after you suspect poisoning.

THE LOST WAYS II

In fact the best way to take activated charcoal is as a series of smaller doses. If you've used Size 0 capsules each of them will contain about half a gram of charcoal. If the victim is an adult they should take four right away, then another four every ten minutes until either the symptoms start to fade or they get to medical help.

Remember that charcoal won't do anything about any poison that's already made it into the body; it can only absorb what's still in the stomach and digestive tract. If possible you should get medical attention if you think someone's been poisoned.

As long as you keep your activated charcoal capsules dry and in a sealed container they should last just about forever. The gelatin capsules will keep the charcoal away from any contamination in the air, and your home-made medicine will always be ready when you need it.

THE LOST WAYS II

HOW TO RENDER LARD AND HOW TO PRESERVE MEAT IN IT LIKE THE PIONEERS

- By Aaron -

“The revelation to store food may be as essential to our temporal salvation today as boarding the ark was to the people in the days of Noah.”

- Ezra Taft Benson

In the 19th century, lard was used in American households similarly to butter. It was a cooking and baking staple, a fuel, but also a way to preserve meat.

In 1854 J. Stonesifer of Boonesborough patented a lamp that specifically used lard as fuel. A screw-driven piston forced lard up into the chamber around the wick, where it burned to form an efficient source of

portable light. A tin loop handle with a hole in it was used for hanging.¹

Lard's popularity decreased during the Industrial Revolution as vegetable oil become more affordable and common.

In the 20th century it was used as a substitute for butter during World War II. By the end of the century, it was considered to be less healthy than vegetable oil, but recent studies suggest otherwise.

Rendered lard can also be used to make soap, a chapter which you can find in *The Lost Ways*. It was also applied as a poultice to burns, cuts, and inflamed areas.

It can be used as a balm moisturizing and protecting the skin from chapping and cracking. You can also mix it with beeswax and use it to refurbish and maintain wood and leather.

The best use for lard is for preserving meat. Meat will last up to a year if it's conserved in lard.

How to Render Lard

¹ Klebe D., 19th Century Lard Lamp - Early Lighting

THE LOST WAYS II

The first step is preparing the fat. I used the back fat, but leaf fat can also be used. This fat was fresh, so I left it to cure with salt for two days.



Chop the fat into small pieces as equally as you can, about ½" square.



Put them in a pot on medium heat.

THE LOST WAYS II



Stir every minute or so for the first ten minutes with a wooden spoon and afterwards every five minutes.

It's good to add a little bit of water too so that the fat won't stick to the pan. When it really starts boiling, reduce the heat.



THE LOST WAYS II

When the lardons turn golden, remove the pot from the heat and wait for five more minutes before clearing away the lardons. They will continue to cook during that time.



If you remove the pot as soon as they are done, the lard will burn and won't be white. It would still taste great however, and you can still use it.

I used around four and a half pounds of fat, and I kept it on the heat for about 35–40 minutes.

Remove the delicious, crispy lardons with a slotted spoon or with a strainer.

THE LOST WAYS II



Next filter the lard through a fine-meshed sieve.

Place the lard in glass jars or enamel metal containers or pots.



To prevent the jars from breaking, you can either heat them up a little bit before pouring the lard or wait a couple of minutes for the lard to get a little bit cooler. Don't wait too long, however, as it will turn solid, but

you can always heat it up again. The metal containers have to be enamel or the lard will go rancid.

Screw the cap of the jar on tightly after the lard is solid.



The lard will last up to a year, or up to two years if the fat is smoked beforehand. The containers have to be placed in a cool, dry, dark place.

Preserving Meat for a Year with Lard

If you want to preserve meat, cut it into pieces and put it into jars. Then pour hot lard over it, making sure you cover the meat and have at least about an inch of clear lard. Wait for the lard to solidify, and then screw on the caps.

You can use it to conserve raw meat, but it will last only about a month. If you want to conserve it up to a

THE LOST WAYS II

year, you have to smoke the meat beforehand for a couple of days. Then you can fry it and place it in the containers, covering it with lard. You can also do the same with homemade sausages.

The best way to cook this meat is just to put it in a pan with a spoonful of lard until it's hot. The pieces of meat will be very tender and juicy. Be very careful with this preservation method as the meat usually doesn't last more than a couple of months. The jars or metal containers have to be stored in a cool, dry place.



EDIBLE PLANTS YOU CAN FIND IN THE WILD

- By Diane Watkins -

“The time will come that gold will hold no comparison in value to a bushel of wheat.”

- Brigham Young

Before the dawn of agriculture, early man ate a wide variety of wild plants for food, including more than 250 fruits alone. An early study found over a thousand wild plants used by early American Inhabitants. With the development of agriculture, man became less dependent on wild plants and the knowledge of wild plants was not taught.

Scientists have catalogued over 20,000 edible plants, yet most people eat less than 20 different species. In today’s tumultuous world, a knowledge of wild foods could be important to survival.

Where to Gather Wild Foods

Start by identifying the common wild edibles in your backyard or in the local parks and botanical gardens nearby. Be careful where you gather plants with the intention of consuming them, use a guidebook and be sure of your identification. Follow these safety guidelines for gathering:

- ❖ Always identify the plant you are gathering. Use pictures and physical characteristics, if you do not have first-hand knowledge of the plant. Take along a field guide whenever possible.
- ❖ Pick only as many plants as you need, and always leave plants behind to replenish the field.
- ❖ Do not eat plants that grow in areas that have been sprayed with chemicals or that grow in polluted waters.
- ❖ Avoid plants that grow near busy roadways, they may contain high concentrations of lead and other harmful chemicals from exposure to car exhaust.
- ❖ Plants growing in contaminated waters should be considered contaminated. Where *Giardia lamblia* or other parasites are common, boil or disinfect plants before eating.

- ❖ Never gather and eat wild mushrooms unless you are an expert in dealing with mushrooms, it is easy to make a deadly mistake.
- ❖ Do not pick rare or endangered plants.
- ❖ Eat only small amounts of wild plants the first day, increasing your consumption of any one plant slowly. Your system may not tolerate all plants, or you may have unknown allergies.
- ❖ Whenever possible, introduce wild plants to the diet one at a time. This way, if you have a reaction to a plant, you will know which one to avoid.
- ❖ Wash and clean all plants before eating.
- ❖ Never eat any fruit or plant that is starting to spoil or that is growing mildew or fungus.
- ❖ Eat only the plant parts identified as safe.

The Universal Edibility Test

In a survival situation, you may not have your field guide to edible plants available, and yet, you need to eat. In such a survival situation, there is a test you can use to determine that a plant or fruit is edible. If you have a reaction at any point during the test, stop the test and choose a different plant or plant part.

Follow these steps:

1. Choose a plant that is abundant in the environment and that you believe to be edible.

THE LOST WAYS II

Test only one part of the plant at a time. For example, test only the leaves.

2. Remove the plant part to be tested from the rest of the plant.
3. Crush the plant and smell it, looking for strong or acid odors, but do not rely on smell alone.
4. Place the crushed plant part on the inside of your elbow or your wrist for 15 minutes. If no skin reaction occurs, you can continue.
5. Wait 8 hours without eating before continuing with the test, drink only purified water. Check your skin again for a rash or irritation. During the test do not eat or drink anything other than the test plant and purified water.
6. Prepare a small portion of the plant part and prepare it for eating. It is usually best to start with a cooked portion. Some plants have toxins that are easily destroyed by cooking, If you are unable to cook it, you can continue to test it raw.
7. Touch a small portion of the prepared plant to your lip and hold it there for 3 minutes, watching for any burning, itching or any other irritation.
8. If there is no reaction after 3 minutes, put the small sample on your tongue and hold it there, without chewing or swallowing, for 15 minutes.

THE LOST WAYS II

9. If there has been no reaction, chew the portion thoroughly and hold it in your mouth for another 15 minutes without swallowing.
10. If you still have not experienced any burning, itching, numbing, stinging or irritation of any kind, swallow the small portion, but only that one small bite.
11. Wait another 8 hours without eating. If you have any ill effects during the wait time, induce vomiting and drink plenty of water.
12. If you have no reaction to the first bite, eat a small portion of the plant, approximately 1/4 cup, prepared in the same way and wait another 8 hours. Again, induce vomiting and drink plenty of water if you experience any ill effects.
13. If there is still no reaction to the plant, consider the tested plant part safe to eat as prepared. Other parts of the plant will need to be tested in the same way before eating. Increase amounts eaten slowly. Remember that large portions of an unfamiliar plant can cause diarrhea, nausea or cramping on an empty stomach, so eat even safe plants in moderation.

Acorns and the Oak Tree, *Quercus* and *Lithocarpus*



Identification. There are about 600 species of oak trees and shrubs. The trees are either deciduous or evergreen with spirally arranged leaves and leaves with lobate or serrated leaves. A few species have leaves with smooth margins. Acorns are the nut of the oak tree. The edible nut is covered in a cup shaped shell containing a single seed and topped with a cap.

Edibility. Acorns have traditionally been used as forage for pigs, but they are also edible for human use. Gather acorns in the fall and store them whole in a cool, dry place for use throughout the winter. Because

² Photo by David Hill - CCA 2.0

acorns contain bitter tannins, which can hinder digestion, they need to be cracked, chopped and soaked in several changes of water before eating. Soak them until the water no longer turns brown, then cook or dry for use as a flour. Acorns can also be used as a coffee substitute.

As a Remedy. Oak has been used as a medicine to treat bleeding, swelling and dysentery. It functions as a diuretic and as an antidote for poison. Dried and powdered root controls bleeding, reduces swelling and prevents infection. Powdered root was also used as a snuff to treat tuberculosis. Poultices or compresses made from the leaves promote wound healing, treat rashes, irritations and reduce swelling.

Amaranth, *Amaranthus retroflexus*

Identification. Amaranth is an edible weed common to most continents. Densely packed flowers grow on stems during the summer or autumn. There are over 60 species of amaranth with red, purple, green or gold flowers.

Edibility. All parts of the plant are edible, but watch for small spines that appear on some leaves. Like many greens, amaranth leaves contain oxalic acid, so it is recommended that you boil the leaves if you are eating them in quantity or often. A few raw leaves in a

salad is safe. Harvest amaranth seeds to make a gluten-free grain that is easy to harvest and cook like rice.



As a Remedy. The amaranth seed contains squalene, notable for its anticancer and antioxidant agents. Squalene is estimated to have three times the antioxidants as vitamin C. The leaves, grain and oil of Amaranth, eaten regularly, have been shown to protect the body from cardiovascular disease and helps to lower blood pressure naturally.

³ Photo by Kurt Stüber, CC- 3.0

Asparagus, *Asparagus officinalis*

Identification. The same asparagus that we pay dearly for at the supermarket also grows wild. Wild stalks are usually much thinner than the supermarket vegetables, but they can be used in all the same ways. Asparagus is a perennial, herbaceous plant with many stems, feathery foliage and bell-shaped white to yellow flowers.



Edibility. Gather young asparagus shoots in the spring, before the leaves begin to open. The shoots turn

⁴ Photo By SeanMack - Own work, CC BY-SA 3.0

woody as the leaves appear. Eat them raw, steamed, or boiled.

As a Remedy. The leaves and the shoots have a cleansing effect on the digestive system, kidneys and liver. The roots are used as a diuretic and laxative and can reduce blood pressure. They are also used to relieve symptoms of dropsy, gout and rheumatism. The powdered seeds can be used as an antibiotic or to relieve nausea.

Autumn Olive, *Elaeagnus umbellata*

Identification. Autumn Olive is an invasive shrub in the central and eastern United States. It is often found in old fields and on roadsides. It is identifiable by the small silver speckles covering the leaves and berries.

Edibility. In the fall, the autumn olive produces an abundance of edible red berries. While the berries are edible raw, they are very sour. The flavor is greatly enhanced by cooking them with sugar. The seeds can be eaten with the berries, either raw or cooked, however the seed coating is very fibrous. The berries can be dried for use as a tea. The leaves and flowers can be used to make a tisane. Since little research has been done on this plant, it is advised that pregnant women avoid it.



As a Remedy. Autumn olive is currently being investigated for its ability to prevent and reverse the growth of cancers. The flowers are astringent and used as a cardiac tonic and as a stimulant. The seeds are used to treat a cough, while oil pressed from the seeds is used to treat lung problems.

Beech, Fagus grandifolia

Identification. The American beech is deciduous, growing 66 to 115 feet tall. The trunk and branches are covered with a smooth, silver-gray bark. Leaves are dark green with serrated edges.

⁵ Photo by Eigenes Werk

THE LOST WAYS II



6

Edibility. The inner bark, young leaves, and the nuts of the American Beech tree are edible. In times of scarcity, beech sawdust has been added to flour to extend it when baking. The sweet seeds are edible raw, but should not be eaten in large quantities because of the fagin content in the skin. Roasting the seeds allows the skin to be easily removed, along with the offending fagin. Crush and boil the seeds to make a nourishing drink or grind them to use like cornmeal for baking.

As a Remedy. The leaves and bark are used to reduce inflammation and treat ulcers. The leaves calm the stomach and nervous system. Boiled leaves made into

⁶ Photo by Fritzflohrreynolds – Own Work, CC BY-SA 3.0

a poultice soothe and heal burns and help repair skin damage from frostbite. Ground beech nuts have been used as medicine for headaches, vertigo, epilepsy and hydrophobia and for de-worming.

Balsam Fir, *Abies Balsamea*



Identification: The balsam fir is native to eastern and central Canada and the northeastern United States. It is a medium-size coniferous evergreen growing up to

⁷ Photo By U.S. Fish and Wildlife Service - Public Domain

THE LOST WAYS II

89 feet tall, although most trees are between 46 and 66 feet tall. The flat needles are dark green and the bark is smooth and grey with resin blisters. It is commonly grown as a Christmas tree in the United States.

Edibility. The inner bark is edible when chewed or cooked. It can be dried and pounded into a powder for use as a flour and thickening agent. Young tips of shoots can be used as a tea substitute.

Caution: Some people are allergic to balsam fir and develop a contact dermatitis when exposed to the leaves.

As a Remedy. The bark, needles and resin are common treatments for a variety of illnesses. The needles are high in Vitamin C and useful as a tea to treat poor health, colds, coughs, bronchitis, colic, asthma, rheumatism, bladder inflammation, sciatica, lumbago, epilepsy, swollen glands, and prevent scurvy.

Smoke from burning needles are useful to treat congestion and headaches. Resin from the bark blisters is used to treat wounds, sores, and skin diseases.

Black Cohosh, *Cimicifuga Racemosa*



Identification. It is also known as black snakeroot, black bugbane, and fairy candle. Black cohosh is a member of the buttercup family native to eastern and central North America. It prefers woodland habitats and has star-shaped flowers that grow on stems up to 8 feet tall. The plant has an unpleasant odor which repels insects.

Edibility. Black cohosh is not edible. It is used as an herbal remedy in small doses.

⁸ Valérie75 assumed (based on copyright claims). - No machine-readable source provided. CC BY-SA 3.0

As a Remedy. The roots and rhizomes have been used historically to treat arthritis and muscle pain. Extracts from the plant are analgesic, anti-inflammatory, and act as a sedative. Currently, black cohosh extracts are used as an herbal remedy for menopause symptoms, to treat menstrual cramps, induce labor, and is sometimes used as a hormone replacement therapy. Avoid black cohosh if you are pregnant or lactating. It can induce miscarriage or harm young children. Women who have or have had breast cancer should also avoid it.

Side effects include headaches and skin rashes; extended use can cause liver damage.

Blackberries

Identification. Blackberry vines have red branches, long thorns, and wide leaves with jagged edges. The white flowers bloom in the spring and berries ripen in the fall. “Blackberries are red when they are green,” so wait until they turn black to harvest them.

Edibility. Use the soft fruit raw or cook it into jams, jelly, desserts or make wine. The roots can be eaten when boiled long enough to soften them. The dried leaves are used in herbal teas. Young shoots of the plant are edible raw if harvested as the first sprout in the spring.



9

As a Remedy. The root-bark and leaves are diuretic, cleansing, and strongly astringent. They are used as a remedy for dysentery, hemorrhoids, cystitis, and diarrhea. Use the roots to make a mouthwash and gargle to treat sore gums, mouth ulcers and sore throats. The leaves can also be used to make mouthwash and to treat thrush.

Black Locust, *Robinia pseudoacacia*,

Identification. It is also known as false acacia. The deciduous black locust tree is native to the southeastern United States and widely naturalized in other parts of the country. It is also found in Europe,

⁹ Photo by Ragesoss, CC-SA 3.0

THE LOST WAYS II

South Africa and Asia. The tree reaches 40 to 100 feet in height in an upright manner. The tree has compound leaves, each containing many leaflets.

Edibility. The bark and leaves of the black locust are toxic, but the flowers are edible. They make a delicately flavored jelly. Shelled seeds are also safe to eat, both raw and boiled.



¹⁰

As a Remedy. The flowers are used as a laxative, emollient, diuretic and antispasmodic. Cooked flowers are eaten to treat eye problems. The inner bark and root-bark are emetic, purgative and tonic. Hold the root bark in the mouth to relieve pain from a

¹⁰ Photo By Mehrajmir13

toothache or chew it to induce vomiting. Juice from the leaves is said to inhibit viruses.

Bloodroot, *Sanguinaria Canadensis*



¹¹

Identification. It is also known as bloodwort, redroot, red puccoon, and pauson. Bloodroot is a perennial herbaceous flower found in eastern North America. It has variable leaf and flower shapes, but is identifiable by the reddish rhizome with bright orange juice.

Edibility. Bloodroot produces the toxin sanguinarine, which are stored in the rhizome. No part of the plant

¹¹ Photo by UpstateNYer - Own work, CC BY-SA 3.0

or root are recommended for internal use. Ingested bloodroot extract can cause nausea, vomiting, headaches, and may lead to a loss of consciousness.

As a Remedy. Bloodroot has been used as a herbal remedy for skin cancer. Applications of bloodroot or its sap to the skin can destroy cells, including cancerous cells. There is no way to determine whether all of the cancerous growth has been eliminated, and the cancer can return. Since some healthy cells are also killed, it can leave ugly scars.

A tea made from the root has been used for sore throats, fever and body aches.

Blueberry, Cyanococcus, American Blueberry

Identification. Blueberries grow on upright shrubs of up to 13 feet in height. Leaves can be evergreen or deciduous and the white, pink or red flowers are bell-shaped. The berries are deep blue to dark purple when ripe, usually in mid-summer.

Edibility. Eat the fruit raw or cooked.

As a Remedy. Blueberry juice has been used as a treatment for diseases of the urinary tract and the prevention of cystitis. It also helps prevent or dissolve

kidney stones. Blueberries are high in antioxidant compounds and may help protect against oxidative DNA damage of aging and prevent cancer.



¹²

They help lower blood pressure and prevent heart disease. Several studies have shown that blueberries, eaten regularly, help improve insulin sensitivity and lower blood sugar levels.

Bull Thistle, *Cirsium vulgare*.

Identification. It also known as spear thistle or common thistle. Bull thistle, a member of the daisy genus, is commonly found throughout North America,

¹² Photo by PhreddieH3, Public Domain

THE LOST WAYS II

Europe, Asia, Africa, and Australia. It is a biennial, forming leaves and a taproot the first year and flowering in the second year.

Edibility. The stems are edible peeled and steamed or boiled. The tap root can be eaten raw or cooked. Harvest the plant in the first year, before it flowers. Once the plant flowers, it is too bitter to be enjoyable.



13

Use as a Remedy. The roots and plant have been used in a poultice for sore jaws or as an herbal steam for treating rheumatic joints. An infusion of the whole

¹³ Photo by Olivier Pichard, CC – SA 3.0

plant has also been used externally or internally as a treatment for bleeding piles.

Bunchberry, *Cornus Canadensis*,



¹⁴

Identification. It is also known as Canadian dwarf cornel, Canadian bunchberry, quatre-temps, crackerberry, creeping dogwood. Bunchberry is a small, erect perennial that grows 2 to 8 inches tall in the northern United States and Canada. The upper

¹⁴ Photo original: JohnHarvey; derivative: Peter Coxhead, CC BY-SA 3.0

leaves form a whorl, while the lower leaves are opposite. The fruit are bright red berries in a bunch.

Edibility. Both the fruit and leaves are edible. Eat the fruit raw or cooked, or dry it for later use. Eat the leaves raw or boiled.

As a Remedy. Leaves applied to wounds and sores help stop bleeding and promote healing. The leaves and berries are useful as a treatment for the common cold.

Burdock, *Arctium lappa*

Identification. Burdock is a medium to large plant with large, dark green leaves and purple, thistle-like flowers. The coarse, oval leaves can grow up to 28 inches long, with lower leaves being heart-shaped.

Edibility. You can eat the leaves and peeled stalks raw or cooked. The leaves taste bitter, but much of the bitterness can be removed by boiling them twice, changing the water each time.

The tap roots are also edible when peeled and boiled. The root is crisp and has a mild, sweet flavor that is improved by soaking the cut roots in water for a few minutes before cooking.

THE LOST WAYS II

Immature flower stalks can be harvested and eaten in the late spring, before the flowers appear. The taste is reminiscent of artichoke, a relative of burdock.



15

As a Remedy. Dried burdock is considered a diuretic, diaphoretic and blood purifier. Oil from the root is used as a scalp treatment. Taken internally, it increases circulation to the skin, helping to detoxify it and treat skin abscesses, acne, carbuncles, psoriasis, eczema and similar skin diseases. Burdock root is also good for helping in cellular regeneration, treatment of Crohn's disease and diverticulitis, treatment of Hepatitis, and Chronic Fatigue Syndrome.

¹⁵ Photo is by Epukas, public domain.

Burdock is high in inulin, a carbohydrate that is helpful for diabetes and hypoglycemia.

Cattail, *Typha*



16

Identification. Usually found near freshwater wetlands, cattails are semi-aquatic perennials with hairless flat blade leaves and a unique flowering spike. The plants grow to heights of 3 to 10 feet.

¹⁶ Photo by Derek Jensen (Tysto), Public domain

In some areas, cattails are considered endangered and it is illegal to pick them and in others they are considered invasive. Know your local laws before you plant or harvest this edible plant.

Edibility. The cattails spikes, roots, leaves and stems are edible. The corn-dog like flower spikes are eaten raw like corn on the cob. Boil the leaves before eating. The roots and stems can be eaten raw or boiled.

As a Remedy. Cattail has natural antiseptic properties. A jelly-like substance found between young leaves can be used on wounds, boils, sores and rashes, and as a powerful analgesic taken internally or used topically to relieve pain and reduce inflammation. The plant has coagulant properties, aiding in blood clotting and providing relief from menstrual bleeding.

Clover, *Trifolium*

Identification. Clover can be found in most open grassy areas. They are small ground cover plants, easily recognized by their distinctive trefoil leaflets. Most clover will grow in sets of three leaves, but consider yourself lucky if you find sets of four, and sets with more leaves have been noted.

Edibility. You can eat clover leaves and stems raw or boiled.



17

As a Remedy. Red clover has been used to treat cancer, whooping cough, respiratory problems and skin irritations. It is known to contain isoflavones which have estrogen-like effects in the body and have shown potential in the treatment of hot-flashes, and other menopause symptoms.

White clover leaves are used in a tea to treat coughs, colds, and fevers. Tea made from the flowers treat rheumatism and gout.

¹⁷ Four leaf clover, photo by Joe Papp, CCA 3.0

Chicory, *Cichorium intybus*,



18

Identification. It is also known as also known as blue daisy, blue dandelion, blue sailors, blue weed, bunk, coffeeweed, hendibeh, horseweed, ragged sailors, succory, wild bachelor's buttons, and wild endive. Chicory grows as a small perennial, herbaceous bush with blue, lavender or white flowers. The stem is tough, hairy and grooved when flowering and grows to be up to 40 inches tall. The leaves are shaped like a lance tip. Flowers appear from July until October and are usually blue, but occasionally pink or white.

¹⁸ Photo By Lmmahood

Edibility. The entire plant is edible, but the leaves are bitter. Reduce the bitterness by boiling them and discarding the water. Use the leaves raw or boiled. The roots are tasty boiled and make a good substitute for coffee when roasted and ground.

As a Remedy. Root chicory is effective against intestinal worms and internal parasites. Chicory flowers are used as a folk medicine as a tonic and as a treatment for gallstones, stomach upsets, sinus problems and cuts and bruises. A poultice of the roots is useful against chancres and fever sores. It contains inulin, which may help with weight loss and helps in blood sugar regulation in diabetics.

Chickweed, *Stellaria media*

Identification. It is also known as chickenwort, craches, maruns, and winterweed. Chickweed sprouts in the late fall or winter, then grows large matts of plants. Leaves are opposite and oval. The plant produces small white flowers with lobed petals. There are several closely related plants which are not edible, but *Stellaria media* is easily distinguished from related plants by a close examination of the stems. Edible chickweed has fine hairs on only one side of the stem and on the sepals. Inedible species have fine hairs covering the entire stem.



Edibility. Chickweed leaves are eaten raw in salads or boiled as a leaf vegetable. The plant contains saponin, which can be toxic when eaten in large quantities.

As a Remedy. Used as an herbal remedy to cool and soothe itchy skin and treat pulmonary diseases. It's high iron content makes it a valuable treatment for iron-deficiency anemia. It is used to treat skin diseases, rheumatic pains, arthritis and menstrual cramps. A tea made from stems can be applied externally to treat bruises and aches and pains.

¹⁹ By Kaldari - Own work, CC0,

Chufa Sedge, *Cyperus esculentus*



Identification. Chufa sedge, also known as nut grass, yellow nutsedge, tiger nut sedge or earth almond, is a sedge grass native to most of the Western Hemisphere, Southern Europe, Africa, the Middle East, Madagascar, and India. It has become naturalized in many other parts of the world. Chufa is an annual or perennial plant that grows up to 3 feet tall.

Chufa has triangular stems that bear slender leaves and spikelets with flat, oval seeds, surrounded by four

²⁰ Photo by Dr. Stanley Kays, Copyrighted Free Use

hanging bracts. The plant is very fibrous and is often mistaken for a grass. Chufa is valuable for its edible tuber, called tiger nuts or earth almonds. The roots are extensive, with scaly rhizomes and small edible tubers.

Edibility. The tubers have a slightly sweet, nutty flavor. They are hard and require soaking in water to soften them before eating. Grind them into a flour for baking or to make tiger nut milk. The tuber is high in fats, starch, and protein and makes an excellent food source.

As a Remedy. Chufa tubers have been used as a treatment for intestinal worms and bloating. It is a powerful uterine stimulant and is also used as an antidiarrheal, aphrodisiac, digestive treatment and tonic. Chufa milk is packed with nutrients and vitamins that support healing and protect the skin.

Cleavers, Galium aparine

Identification. Cleavers, also known as goosegrass, clivers, catchweed, stickyweed, sticky willy, sticky willow, and robin-run-the-hedge, are an annual that grow along the ground, attaching themselves with small hooked hairs on the stems and leaves. Tiny white to greenish star-shaped flowers appear in early spring to summer in clusters of two or three. Leaves are arranged in whorls of six to eight.



Edibility. Some people get an unpleasant rash from contact with cleavers and should not eat it. For most, *Galium aparine* is edible. Gather the leaves and stems before the flowers appear and use them as a cooked vegetable. Dry and roast the fruits for use as a coffee substitute.

As a Remedy. A poultice made from cleavers is used on wounds, ulcers, seborrhea, eczema, psoriasis, and other skin problems. An infusion made from the plant is used to treat glandular fever, tonsillitis, hepatitis, cystitis, and urinary problems.

The juice has a mild laxative effect and is a diuretic. Fresh or dried cleavers is anti-inflammatory, astringent, cleansing, and tonic. It relieves constipation and induces sweating.

Crab Apples, *Malus*



²¹

Identification. Crab apples, also known as wild apple, are compact ornamental trees that grow wild. The genus contains up to 55 species of small deciduous apple shrubs and trees native to the temperate zone of the Northern Hemisphere.

²¹ Photo By Wehha - Own work, CC BY-SA 3.0

Edibility. The fruit is a smaller, more sour version of the domestic apple. Eat them raw or sweeten them to make applesauce, pies, jelly and juice. The leaves can be used to make a tasty tea.

As a Remedy. Many parts of the crab apple tree are used as herbal remedies: The fruit is astringent and useful as a laxative. A poultice made from crushed fruit helps heal inflammations and wounds. The root-bark is useful against worms and parasites and as a sleep inducer. A root-bark infusion is used in the treatment of fevers.

The leaves contain antibacterial agents. Seeds of the crab apple contain toxic hydrogen cyanide which has been claimed to be beneficial in the treatment of cancer, but they are poisonous in large quantities.

Curled Dock, *Rumex crispus*

Identification. Curled dock grows wild in Europe, North and South America, and Australia. It is recognizable by its tall red stalks, reaching up to 3 feet in height. Smooth leaves grow from a large basal rosette with wavy or curled edges. Flowers and seeds grow in clusters on the stem.

Edibility. Peel and eat the stalk raw or boiled. The leaves are best boiled in several changes of water to

remove their bitterness and oxalic acid. Harvest curled dock while young, the mature plants are much too bitter.



122

As a Remedy. Curled dock has been used as a gentle laxative for the treatment of mild constipation. It has cleansing properties and is used internally to treat diarrhea, piles, bleeding in the lungs, and chronic skin diseases. A poultice or salve made from the roots is used on wounds, sores, ulcers, and other skin problems. The root can also be dried and applied as a powder.

²² Photo by Olivier Pichard, CCA 3.0

Dandelion, *Taraxacum officinale*



23

Identification. This common weed has very small yellow to orange flowers growing together on a composite flower head and appearing to be one flower.

The leaves are 2 to 10 inches long lobed and grow in a basal rosette from the taproot. Both the stems and leaves produce a sticky white, milky sap when broken. The seeds form a puff ball which is easily dispersed by the wind.

²³ Photo By Greg Hume - Own work, CC BY-SA 3.0,

Dandelions are very similar to catsear, and can be distinguished by their unbranched, hairless, leafless, and hollow stems which hold only one flower.

Edibility. The entire plant is edible, including the roots. Young leaves are tender, but they develop a bitterness as they mature. Boil them in several changes of water to reduce the bitter taste. Boil the roots to eat and drink the cooking water as dandelion tea. Eat the flowers raw as a garnish on your salad. Dandelions are also used to make wine.

As a Remedy. The dandelion is a common herbal remedy, effective as a cleansing agent, diuretic, laxative, tonic and as a potassium supplement. All parts of the plant can be used, but the root is most effective. It is also used to purify the liver, treat gallstones, urinary problems, skin diseases, gout, jaundice, and stomach upsets.

Elderberries, *Sambucus*

Identification. Elderberry shrubs grow to be 10 to 25 feet tall. The leaves are round with serrated edges. Identify the plant in the spring by the white flowers and harvest berries in the fall. Ripe berries can be black, red, white or yellow, depending on the species.

THE LOST WAYS II

Edibility. The elderflower blossoms and cooked elderberries are edible. Syrup made from the elderflower blossoms is used as a flavoring agent or diluted to make a drink. A fermented drink is also made from the flowers.

Berries must be cooked, and are eaten in pies or coated in batter and fried. Uncooked berries and other parts of the plant are poisonous.



24

As a Remedy. Black elderberry is used medicinally as a treatment for colds, flu, and allergies by reducing the swelling in mucous membranes and relieving congestion. It is also applied to the skin to treat

²⁴ Photo by Edal Anton Lefterov - Own work, CC-SA 3.0

wounds. Elderberry contains antioxidants and may have anti-inflammatory, antiviral and anti-cancer properties.

Fiddleheads, *Matteuccia struthiopteris*



25

Identification. Fiddleheads, also known as Ostrich ferns, grow in damp areas of North America in the spring. Some other species of ferns are also edible, but check your species before eating. Fiddleheads are the fronds of a young fern, harvested early, while the frond is still tightly curled.

Edibility. Only the closed fiddleheads are edible. Cut them close to the ground, remove the brown husk,

²⁵ Photo by MJ, CC – SA 4.0

and wash them well. Boil them for 15 minutes or steam them for 10 to 12 minutes to kill microbes that they sometimes harbor.

As a Remedy. Fiddleheads have antioxidants and are a valuable plant source of omega-3 and omega-6 fatty acids. An infusion can be gargled to relieve a sore throat. Leaves from the ostrich fern can be applied directly to the skin to treat wounds, infections and boils.

Field Pennycress, *Thalspi vulgaris*

Identification. Field pennycress grows wild in most parts of the world from early spring to late winter. It is a flowering plant in the cabbage family, Brassicaceae.

Edibility. The seeds and leaves of field pennycress are edible either raw or boiled. Be careful where you harvest field pennycress because it accumulates minerals and heavy metals from the soil. Do not eat field pennycress grown in contaminated soils or near the road.



26

As a Remedy. Pennycress is used as a treatment for rheumatic disease and as a diuretic. The seeds are anti-inflammatory and useful for the treatment of fluid in the lungs, and fever.

The entire plant has anti-bacterial activity and is useful as a blood tonic, as an expectorant and a liver tonic. It is useful in treating carbuncles, acute appendicitis, intestinal problems, menstrual problems, endometriosis, and post-partum pain. Use pennycress with caution; large doses can cause nausea, dizziness and a decrease in infection-fighting white blood cells.

²⁶ Photo By Kristian Peters, CC BY-SA 3.0

Fireweed, *Epilobium angustifolium*

Identification. Found primarily in the Northern Hemisphere, this pretty, flowering plant is easily identified by its purple flower and the unique structure of the leaves. The veins in the leaves are circular, rather than running to the edges of the leaves.



27

Edibility. Eat the leaves of fireweed when they are young and tender or use them to make tea. Mature

²⁷ Photo By kallerna - Own work, CC BY-SA 3.0

leaves are tough and bitter. The stalk, flowers, root and seeds are also edible. Scrape and roast the root for a tasty, but sometimes bitter root vegetable.

As a Remedy. Fireweed is used to treat pain and inflammation, reduce fevers and heal wounds. It is also used to treat tumors and enlarged prostate. It is considered a tonic and an astringent.

Foxglove, *Digitalis Purpurea*



²⁸ Photo by Kurt Stüber, CC BY-SA 3.0

Identification. Foxglove is a genus of approximately 20 different plants and shrubs. The plant is often grown as an ornamental for its vivid tulip-shaped flowers. During the first year, only the stem and leaves are produced, and the plant flowers during the second year.

Edibility. The plant is considered poisonous and should be used as a medicinal only under medical advice.

As a Remedy. Digitalis is used as a treatment for atrial fibrillation, a common irregular heart rhythm, and is prescribed, under the drug name digoxin, for heart failure. The dried leaves are used, but taken in excess they can be deadly. An overdose will quickly induce vomiting and nausea to prevent the patient from consuming more. **Foxglove should be used with care only on the advice of a medical professional.**

Garlic Grass, *Allium vineale*

Identification. Garlic grass, or wild garlic is a perennial species of the wild onion. The plant has a strong garlic odor and flavor.

Edibility. Use it as you would garlic. The leaves are edible raw or cooked. The bulb is small, but very flavorful.



29

As a Remedy. *Allium vineale* is an anti-asthmatic, blood purifier, diuretic and expectorant. In children, it is used to treat colic and croup.

Eat the raw root to reduce blood pressure and ease shortness of breath. A tincture is used to treat worms. Garlic grass contains sulphur compounds which help reduce cholesterol levels and act as a tonic for the digestive and circulatory system.

²⁹ Photo by Matthew C. Perry, US Geological Survey, Public Domain

Garlic Mustard, *Alliaria petiolata*



Identification. Garlic mustard, also known as Garlic Mustard, Garlic Root, Hedge Garlic, Sauce-alone, Jack-in-the-bush, Penny Hedge and Poor Man's Mustard, is a biennial flowering plant with clumps of slightly wrinkled leaves that smell of garlic.

Edibility. The flowers, leaves, seeds, and root can be eaten. For best flavor, harvest leaves in the spring; they grow bitter as the weather gets hot. Harvest the horseradish flavored roots in the early spring or late fall.

As a Remedy. The leaves and stems of garlic mustard are useful in treating wounds. They are high in Vitamin C and are used internally to induce sweating and treat bronchitis, asthma and eczema.

Externally, use it as an antiseptic poultice to treat itching of bites and stings, promote wound healing, and treat ulcers and skin problems.

An infusion of roots in oil can be used to make an ointment that relieves bronchitis when rubbed on the chest.

Gooseberry, *Ribes*



Identification. Gooseberry, also known as amla, is found in Europe, Africa, Asia, and in scattered locations in North America. Bushes grow up to 5 feet

tall. Branches are grey with long red thorns. Leaves have 5 lobes with rounded edges.

Edibility. The fruit ripens in late spring to early summer. Ripe fruit may be white, as in the photo above, or red. Gooseberries are edible, but very sour. While they can be eaten raw, most people prefer them in jellies, jams, pies, or other preparations that contain sugar. The fruit can also be pickled or dried.

As a Remedy. Gooseberry, eaten daily, has proven benefits for the control of blood sugar in diabetics (eaten without sugar) and pre-diabetics. It enhances food absorption, supports a healthy heart, fortifies the liver, balances stomach acid and improves mental function.

It is high in Vitamin C and a powerful antioxidant. The leaves are used in many hair tonics to enhance hair growth and add shine. A paste of pounded or dried and ground leaves can be applied directly to the scalp and roots of the hair.

Indian Cucumber Root, *Medeola virginiana*

Identification. Indian cucumber root is a member of the lily family that grows in the forests of the eastern United States. Shoots produce two layers of whorled

THE LOST WAYS II

leaves, the second growing in when the plant flowers. The lower leaves have between five and nine lance shaped leaves, while the upper leaves have three to five ovate leaves. Yellow-green flowers appear in the late spring, followed by dark blue to purple inedible fruit.



30

Edibility. The plant and berries are not edible. The edible tuber has the smell, taste and crispness of a cucumber.

As a Remedy. The crushed and dried leaves and berries make an infusion that has been used as an anticonvulsive. The root is a diuretic and a laxative.

³⁰ Photo By Jomegat - Own work, CC BY-SA 3.0

Green Seaweed, *Ulva Lactuca*



Identification. If you live near the ocean, look for fresh green seaweed in the water. Rinse it with fresh water, if possible and let it dry.

Edibility. Use it raw or cook it in a soup.

As a Remedy. Eating seaweed daily is considered to have many healing benefits. Seaweed is rich in iodine and is helpful in the treatment of goiter and thyroid problems. It is also high in potassium, and is beneficial as a supplement and as a beneficial supplement for fibromyalgia, exhaustion, anxiety and depression.

Because it is high in iodine, it is useful in preventing the adsorption of radioactive iodine in a nuclear event.

Hazelnuts, *Corylus avellane*



31

Identification. Deciduous Hazel shrubs and trees grow to be 12 to 20 feet tall, with rounded, bright green leaves with double-serrated edges. Single-sex catkins of flowers arrive very early in spring, before the leaves. Female flowers are very small, with only the bright-red styles visible. Male flowers are pale yellow and several inches long.

Edibility. The nuts of all hazel trees are edible. Harvest them in mid-autumn when the trees drop their leaves and nuts. Eat the nuts fresh or dried as a snack or use them to flavor baked goods.

As a Remedy. Hazel nuts are a source of vitamin E, the oil is used in the cosmetic industry and as a treatment

³¹ Photo by Simon A. Eugster, CC-SA 3.0

for infection with threadworm or pinworm in babies and children. The bark, leaves, catkins and fruit are astringent and useful for inducing sweating and reducing fevers. They are also used to treat toothaches.

Hickory, *Carya*



³²

Identification. The tree grows to 50 to 60 feet tall with pinnately compound, spear-like green leaves. The small, yellow-green flowers hang from catkins that appear in the spring. Hickory nuts grow enclosed in a husk which opens at maturity in the fall.

³² Photo by Abrahami, CC-SA 2.5

Edibility. Hickory nuts are the edible fruit of the deciduous hickory tree. Eat them raw or cooked and store them over the winter in their shells.

As a Remedy. Small, fresh shoots of the shagbark hickory are steamed to make an inhalant useful for headache relief. Hickory bark tea has been used to treat rheumatism and externally in a poultice on rheumatic joints.

Jerusalem Artichoke, *Helianthus tuberosus*



Identification. Jerusalem artichoke, also known as sunroot, sunchoke, earth apple or topinambour, is the tuber of the *helianthus tuberosus* plant. The plant has

rough, hairy leaves that alternate on the lower part of the plant, but are opposite on the upper part of the stem. The elongated tubers resemble ginger root.

Edibility. The tubers are a crisp addition to a slaw or salad eaten raw. Roasted tubers are used as a coffee substitute. They store well in a cool place and become sweeter with storage.

As a Remedy. Jerusalem artichoke is used as an aphrodisiac, diuretic, laxative, as a stomach remedy and general tonic. It is a folk remedy for diabetes and rheumatism.

Japanese Knotweed, *Fallopia japonica*



Identification. Considered an invasive plant in parts of the United States, Japanese knotweed looks like bamboo or a giant, reddish asparagus. It grows near waterways in sunny locations.

Edibility. The stalks are edible, and at their best in the spring while they are still soft. The flavor is similar to a sour rhubarb and it can be substituted for rhubarb in recipes.

The plant grows in large clumps and is easy to harvest, but do not eat it raw in excess or over a long period as it contains oxalates. Cooking destroys the oxalates and makes it safe to eat in quantity.

As a Remedy. Japanese knotweed contains powerful anti-oxidants that reduce inflammation. It is an excellent source of resveratrol which is useful for its anti-inflammatory and anti-aging properties. It has also been used to lower cholesterol and prevent cancer. Used externally, it is beneficial for skin problems, burns, and wounds.

Joe-Pye Weeds, *Eutrochium*

Identification. Joe-Pye weed is a member of the sunflower family, sporting purple flowers. It is a perennial, growing to 5 feet tall and flowering from July to September.

THE LOST WAYS II

Edibility. All parts of the plant are edible, including the root. Harvest the leaves and stems before the flowers open and dry them for future use. Harvest the roots in the fall and make an herbal tea with the fresh flowers.



As a Remedy. The plant has been used as a medicinal to treat a variety of illnesses including fevers, typhus, kidney stones, and other urinary tract illnesses. Decoctions made from the root and flowers are diuretic and tonic. It is also used to soothe the nerves, treat menstrual problems, impotence, indigestion, asthma, coughs, colds and headaches.

Kelp, *Alaria esculenta*



Identification. Kelp is another seaweed, belonging to the brown algae and found in most parts of the world. It consists of long, flat, blades growing from stem-like stipes.

Edibility. Like green seaweed, eat it raw or use it in a soup.

As a Remedy. Kelp is a valuable source of iodine and is useful to treat goiter and thyroid problems and protects against radiation poisoning. Iodine is important in female hormone regulation and supports the immune system. It also contains enzymes that help

³³ Bjørn Christian Tørrissen - Own work, CC3.0

digestion. It has anti-inflammatory benefits and offers therapeutic potential for neurodegenerative diseases. Caution: Some people are allergic to kelp and may experience symptoms such as rashes, hives, itchy eyes, runny nose, shortness of breath, or gastro-intestinal problems.

Kudzu, Japanese Arrowroot



Identification. If you have kudzu growing near you, it is an almost limitless source of food. Often found climbing over trees, shrubs, even abandoned houses, the plant is fast growing and considered invasive in most areas.

Edibility. The entire plant is edible. The roots are starchy and eaten like potatoes, while the leaves are

eaten raw or cooked like a green. Jelly or tea is made from the flowers.

As a Remedy. Kudzu is used to treat muscular aches, headaches and migraines, heart disease and angina, allergies and diarrhea. Kudzu should not be taken by pregnant and lactating women.

Lamb's Quarters, *Chenopodium*



Identification. The plant is also known as goosefoot or pigweed and grows in clumps of 6 to 9 feet tall plants. It has pale green, waxy leaves that are whitish on the underside. Caution: Nettleleaf goosefoot is a poisonous plant that looks like lamb's quarter. It can

be distinguished by the undesirable odor of nettleleaf goosefoot.

Edibility. Harvest lamb's quarters when the leaves are young, before the flowers appear. If consistently harvested, they can be eaten throughout the summer, until the first frost.

The leaves contain oxalic acid, so eat them raw in moderation or cook them like spinach to destroy the oxalic acid. The leaves can also be dried and powdered to make flour

As a Remedy. Lamb's quarter are high in vitamins and minerals, it is one of the most nutritious wild foods. The plants can be made into a poultice to relieve pain from rheumatism and arthritis and to relieve swelling and inflammation. Chew raw leaves to relieve toothaches.

Mayapple, *Podophyllum*

Identification. Mayapple, also known as American mandrake, wild mandrake and ground lemon, grows wild in most of the eastern United States and southeastern Canada. The plants grow in clusters originating from a single root.



Edibility. The plant is extremely poisonous, including the green fruit. The fruit becomes edible when it is fully ripe and has turned yellow and softened. Remove the seeds before consuming. Be careful when handling the plant; the toxins can be absorbed through the skin.

As a Remedy. Mayapple plant is poisonous and should not be eaten. While it has been used as an herbal remedy and to induce miscarriages, it is easy to overdose and poison the patient.

Mustang Grapes, *Vitis mustangensis*



34

Identification. Mustang grapes, also known as wild grapes, are common along riverbanks and in moist locations throughout the southeastern United States. The vines are woody and produce small cluster of grapes that ripen into dark purple grapes in August to September. The skin of the grape is thick. The leaves are easily recognized by the white velvet-soft underside of the leaf.

³⁴ Photo by Ddal, CC-SA 3.0

Edibility. The fruit are extremely acidic, but very tasty used in jelly or as a juice, sweetened with sugar. It is also a popular fruit used for winemaking. The leaves are often eaten in “dolmades”, cooked and stuffed with a mixture of rice, meat and spices.

As a Remedy. No known use.

Miners Lettuce, *Claytonia perfoliate*



Identification. It is also known as Indian lettuce, spring beauty, or winter purslane. Look for miner’s lettuce in cool, damp conditions. This herbaceous annual grows

from a rosette at the base. Small pink or white flowers appear in the early spring to early summer.

Edibility. The flowers, leaves and roots of miner's lettuce are all edible either raw or cooked like spinach. The young leaves are fairly bland, but the flavor becomes more bitter as the leaves mature.

The roots are also edible raw or cooked. Although small and a chore to harvest, the root bulbs have the flavor of chestnuts when boiled and peeled.

As a Remedy. The plant is rich in vitamin C and can be used as a tonic, diuretic, or a gentle laxative. A poultice made from macerated plants is used to relieve the pain of rheumatic joints.

Monkey Flower, *Erythranthe*

Identification. Erythranthe, also known as musk flower, is a diverse plant genus. The plants are usually annuals or herbaceous perennials with red, pink or yellow flowers. They often grow in damp or wet soils.

Edibility. Harvest monkey flower stems and leaves before the flowers appear for best flavor. The flowers are also good in salads or used as a garnish. Use monkey flower leaves raw or cooked like greens.



35

As a Remedy. Erythranthe is listed as one of plants used to prepare Bach flower remedies.

Cautions: Monkey flower species tend to concentrate salts in their leaves and stems, so early travelers used them as a salt substitute.

Several species of Erythranthe are listed as threatened; investigate your supply before harvesting.

³⁵ **Photo by** Christophermluna, CC-3.0

Pecans, *Carya illinoensis*



³⁶

Identification. The pecan is a large deciduous tree, growing up to 100 feet tall. They have alternate leaves, 12 to 18 inches long and pinnate with 9 to 17 leaflets.

Edibility. The seeds, technically a fruit, but recognized as a nut, are edible. Most people are familiar with the pecan nut, but may not recognize it covered by its husk. The husk opens and releases the nut to fall to the ground when ripe. Gather nuts under pecan trees in the fall.

³⁶ Photo by Dobbj, CC 2.0

As a Remedy. The bark and leaves of the pecan tree are astringent. A decoction made by boiling the bark was used to treat Tuberculosis. The pounded leaves can be rubbed on the skin as a ringworm treatment.

Persimmon, *Diospyros virginiana*



Identification. Persimmon trees grow throughout the southeastern United States, usually in open woods or fields. The tree is usually about 15 to 30 feet tall, but can grow to 80 feet, with oval leaves and male and female flowers on separate short stalks. Male flowers grow 16 flowers per stem, arranged in pairs, while female flowers grow a single flower on each stem. The fruit are usually small, about 1/2 inch in diameter and bright orange when they ripen in the late fall.

³⁷ Photo by Tduk Alex Lozupone - Own work, CC 3.0

Edibility. Gather the fruit when they are soft and fully ripe. Eat them fresh or use the pulp in jelly, breads, cakes and pies. You can substitute persimmon pulp in any recipe calling for banana pulp. Dried persimmon leaves make a delicious tea that is rich in vitamin C and the roasted seed is used as a coffee substitute.

As a Remedy. Teas made from persimmon leaves act as a diuretic and help reduce high blood pressure. They are also useful as an anti-inflammatory for arthritis or gout. Infusions or decoctions of the persimmon tree bark have antiviral and anti-bacterial properties and are useful for treating colds, coughs and the flu. Externally the infusions of leaves or root decoctions are used to disinfect wounds and help healing. They can also be applied to reduce pain and inflammation, including the inflammation of hemorrhoids.

The unripe persimmon fruit are very astringent and can be used to treat diarrhea. Eating the ripe fruit helps lower cholesterol.

Pine Trees, *Pinus*

Identification. Pine trees are evergreen conifers growing 10 to 260 feet tall. Most pines have thick, scaly bark, but a few have thin, flaky bark. Branches

THE LOST WAYS II

grow in a tight spiral, producing needles and seed cones.



Edibility. The soft, white, inner bark of all pine trees is edible. It can be eaten raw or dried and ground into a powder for use as a flour or thickener in cooking. Young, green pine needles can be steeped in boiling water to make a tea that is high in vitamins A and C.

All pine trees bear edible nuts, but most are very small. They are a good source of protein, fat, and carbohydrates.

Harvest pine cones at the end of summer or early fall, before the cones have opened. Wear gloves and old clothes, the pine sap causes a sticky mess. Gather unopened or half-opened cones from the tree, pulling

them off the tree or knocking them down with a stick. Cones on the ground will usually have already opened and released their nuts.

Pick the nuts out of half-opened cones immediately, then shell them and toast or eat them raw. Put the unopened cones in a burlap or fabric sac with good air flow and hang them outside to ripen. The first freeze will force the cones to open enough that you can pick the seeds out.

If you don't want to wait, bury the closed cones in the ashes of a hot fire and allow the heat to open the cones. Don't try to put them directly into the fire, they burn very hot and can pop, throwing hot nuts onto nearby diners.

As a Remedy. Pine sap is a natural disinfectant and antiseptic with both antimicrobial and antifungal properties. Apply it directly to wounds to stop blood flow and disinfect the wound.

Pineapple Weed, *Matricaria discoidea*

Identification. Pineapple weed, also known as wild chamomile, and disc mayweed, is an annual in the Asteraceae family, growing 2 to 16 inches tall. Cone-shaped flowerheads holding densely packed yellowish

green corollas appear from March to September. The crushed flowers have a definite pineapple and chamomile scent.



38

Edibility. Pineapple weed flowers and leaves are edible raw in salads or brew to make an herbal tea. When crushed, the flowers have the aroma of pineapple and chamomile. The plant has also been used for medicinal purposes to relieve upset stomachs, fever and fight infections.

³⁸ Photo by Krzysztof Ziarnik - Own work, CC 3.0

As a Remedy. Pineapple weed is rarely used medicinally, although it has been used in the past to treat intestinal worms and as a sedative.

Plantain, *Plantago*



³⁹

Identification. This is not the banana like fruit, but rather a green plant that grows in wetlands, marshes, bogs, and alpine forests. The oval leaves have vertical ribs and can grow to be up to 6 inches long and 4 inches wide.

³⁹ Photo by Iorsh , Public Domain

Edibility. The leaves are edible at all times, but they grow more bitter as they mature. Use them raw in salads or cook them as a pot herb.

As a Remedy. Plantain roots are used in a wide range of remedies, including: stomach upsets, peptic ulcers, diarrhea, Irritable bowel syndrome, hemorrhoids, cystitis, bronchitis, sinusitis, asthma, coughs, hay fever. It causes a natural aversion to tobacco and is used in smoking cessation programs. The root is also rumored to be an anti-venom for rattlesnake bites.

Heated leaves made into a compress are useful for skin inflammation, wounds, ulcers, stings and inflammation.

Ground plantain seeds act as a laxative and are used for the treatment of parasitic worms.

Prickly Pear Cactus, *Opuntia compressa*, *Opuntia drummondii*, and *Opuntia vulgaxis*

Identification. Prickly pears are a cactus that grow in the American west and in the coastal plain region of the southeastern United States. They are native to sandy or rocky soil.

THE LOST WAYS II

Edibility. Prickly pear cactus produce a red or purplish fruit that is covered with tiny spines. You definitely want to wear gloves and handle these fruit with care. The spines are easily removed by securing the fruit in a pair of tongs and holding it over a small flame to burn off the spines. Use prickly pear fruit to make jelly or jam or cook it to extract a nutritious juice.



The green cactus pads, called nopal or nopales, are also eaten. Scrape the bristles off with a knife and trim

⁴⁰ Photo by Cactus.man at English Wikipedia, Public Domain

the pad around the edge. Boil the pads for 10 to 15 minutes and eat them as a vegetable.

As a Remedy. Used fresh, the leaf pars are a diuretic and can be used in a poultice on skin sores and infections. The fruit is packed with anti-oxidants and is anti-inflammatory.

Prunella vulgaris



41

⁴¹ Photo by Jesse Taylor, CC-SA 3.0

Identification. *Prunella vulgaris*, also known as Self-Heal or Heal-all, grows 2 to 12 inches high with creeping stems that root where they land. The stems are square with leaves growing in opposite pairs. Leaves are elongated with serrated edges and a reddish tip.

Edibility. Self-heal is entirely edible. The young leaves and stems are good raw or the whole plant can be cooked and eaten.

As a Remedy. The plant is used medicinally to make a dressing for wounds, ulcers, sores and other skin problems. A tea made from the plant was taken to treat fevers, diarrhea, internal bleeding, nephritis, and goiter. The plant is antibacterial and antiseptic and astringent. Use it fresh and harvest it mid-summer and dry it for later use.

Purslane, *Portulaca oleracea*

Identification. Purslane, also known as verdolaga, pigweed, little hogweed, red root, parsley, is a succulent plant with smooth, flat leaves. It grows from early summer through fall and may grow to 16 inches in height.

THE LOST WAYS II

Edibility. Eat it raw or boiled. The leaves have a sour taste and contain oxalate, but both are reduced by boiling.



42

As a Remedy. Purslane is used to treat and prevent a wide variety of illnesses, including cataracts, dysentery, heart disease, asthma, cardiac arrhythmia, intestinal worms, gum disease, multiple sclerosis, psoriasis, stomach aches, headaches and depression. It is high in vitamins A, C, and E, as well as calcium and magnesium and is thought to boost the immune system.

⁴² Photo by Burschik, CC-SA 3.0

Red Mulberry, *Morus rubra*



43

Identification. Red mulberry trees are native to the eastern and central United States. The tree is deciduous, growing up to 70 feet tall. The leaves are alternate with a sand-paper like upper surface.

Edibility. Red mulberry fruit look a lot like ripening blackberries, but they are less tart. Watch for them to ripen in the late spring to early summer. Pick them as soon as they are ripe, or you will have competition from the local birds.

⁴³ Photo by mauroguanandi, CC-SA 2.0

As a Remedy. Tea made from the root of red mulberry trees is effective against parasitic worms, tapeworms, dysentery, and urinary problems. The sap is useful to treat ringworm. The fruit helps reduce fevers.

Rose, *Rosaceae*



Identification. Roses are a large family with thousands of cultivars. They grow as shrubs and vines and usually have thorns. Flowers are large and often fragrant.

Edibility. The flower petals and rose hips produced by many garden roses are edible. The petals plucked from open blooms are used to make tea, syrups, rose water, and as a flavoring in foods. Rose hips, the mature seed pods from the rose flower, is used to make jams, jellies, marmalades, soups and teas.

As a Remedy. Rose hips, leaves, petals and roots have been used for a wide variety of remedies including treatment of colds, flu, fevers, diarrhea and stomach upsets. Rose hips are highly valued for their vitamin C content.

A boiled tea made from the hips or roots has been used to treat eye infections and inflammations.

The FDA has designated the rose flowers, fruit (hips) and leaves of *Rosa alba* L., *Rosa centifolia* L., *Rosa damascena* Mill., and *Rosa gallica* L. as “Generally Recognized as Safe”.

Seneca Snakeroot, *Polygala Senega*

Identification. Seneca Snakeroot, also known as Senegaroot or Rattlesnake root, is a perennial herb in the milkwort family. It is named to honor the Seneca people, who used the plant as a treatment for snakebite. The plant grows to be 20 inches tall with many unbranched stems. Lance-shaped leaves alternate with smaller lower leaves. The small, pea-like white or greenish flowers grow on a spike. The root has a scent reminiscent of wintergreen and a pungent flavor.

Edibility. The plant and root are for medicinal use only and are not edible. Large doses are poisonous.



44

As a Remedy: Seneca snakeroot is most commonly used as an expectorant in respiratory problems such as colds, croup, and pleurisy. Root tea was also used for pneumonia, bronchitis, whooping cough, asthma, and to calm the mucous membranes. The plant is still used as an herbal remedy for respiratory problems.

Root tea is an emetic, induces perspiration, and helps regulate menses. It has also been used to treat

⁴⁴ Photo by Rob Routledge, Sault College, Bugwood.org - Image Number 5473588 at Forestry Images, The Bugwood Network at the University of Georgia and the USDA Forest Service., CC BY 3.0

rheumatism, heart problems, convulsions, and inflammation.

The Seneca people chewed the root and applied the mash to snakebites after sucking out the poison, hence the name.

Sheep Sorrel, *Rumex acetosella*



Identification. Sheep sorrel is found in the highly acidic soil of fields, grasslands and woodlands in Europe, Asia, and North America. The plant has a reddish stem that grows up to 18 inches tall and green arrow-shaped leaves.

Identification. Sheep sorrel can be eaten raw, but it contains oxalates, so either cook it or eat only small quantities. It has a tart, lemony flavor. Sheep sorrel can also be used as a curdling agent for cheese making.

As a Remedy. The fresh juice of sheep sorrel is a diuretic and is considered detoxifying. It has a mild laxative effect and is used for stomach problems and to expel worms.

A root decoction has been used for excessive menstruation, stomach ulcers and diarrhea.

A tea from the leaves can be used externally to treat boils, abscesses, sores and other skin diseases. Used as a poultice, the leaves reduce inflammation.

Spikenard, *Aralia Racemosa*

Identification. Spikenard, also known as American Spikenard, Petty Morel, Indian Root, Spice berry, and Life-of-man, is an herbaceous plant, growing up to 4 feet tall in moist soil and semi-shade. It is found mostly in the eastern United States. It bears hermaphrodite flowers in early summer.

Edibility. The fruit, leaves, young shoots, and root are edible, mostly used as a flavoring for its liquorice flavor and for making root beer. It can be eaten cooked as a

THE LOST WAYS II

green vegetable. The fruit are tasty eaten raw or cooked.



As a Remedy. American Spicknard has been used as a healing plant for thousands of years. The root's antiseptic, diuretic, detoxifying and diaphoretic properties make it useful as a purifier, and to treat a variety of conditions including coughs and respiratory illnesses, rheumatism and gout.

Applied externally as a poultice, it is used to treat skin problems and rheumatism. The roots can be collected in the summer and fall and dried for later use.

⁴⁵ Photo by Urban - Own work, Public Domain

Spruce, *Picea*



46

Identification. The spruce is a coniferous evergreen tree. Branches are whorled and produce needles attached in a spiral form. It is covered with scaly, reddish-brown bark and grows to be from 60 to 200 feet tall. It produces yellow or red male catkin-like

⁴⁶ Photo by MPF, CC-SA 3.0

flowers and bright purple female flowers in the spring. The resulting seed cones are oblong.

Edibility. All parts of the spruce tree are edible. The needles are used to make a tea, and the inner bark and green cones are palatable, although a little bitter. For an easy snack, chew on a sprig of new growth in the spring. Spruce is a valuable source of vitamin C during the winter months when little else is growing.

As a Remedy. The young shoots and leaves are most often used medicinally. A tea made from young shoots reduces fevers and promotes sweating. It is used to treat coughs, colds and the flu and the inhaled vapors are used for bronchitis.

Use the pitch from spruce trees as an external treatment for wounds, ulcers and sores.

Tea made from shoots or leaves is used for treating bladder infections, scurvy, gonorrhea, and as a general cleansing tonic.

Sunflower, *Helianthus Annuus*, Common Sunflower

Identification. The sunflower is an annual plant in the family Asteraceae, known for its huge flowering head. The plants are annuals or perennials growing to 10

THE LOST WAYS II

feet tall or more. The flower heads have bright yellow ray florets around a yellow or maroon disc with florets inside. The plant tilts to face the sun during the day, until the flower is produced, then they usually face east. Seeds are produced on the disc, the ray flowers are sterile.



47

Edibility. In addition to the popular sunflower seeds, the leaves, flowers and stems are also edible. The seeds are eaten raw or cooked and can be roasted to

⁴⁷ Photo by Fir0002 - Own work, GFDL 1.2

make a coffee substitute. Young flower buds are best steamed, while the leaves and stalks can be boiled and served as a green vegetable.

As a Remedy. A tea made from the leaves is used to treat coughs and fevers. Crushed leaves are used on skin wounds, sores, stings and snakebites. A tea made from the flower is used to treat malaria and lung diseases.

Sweet Rocket, *Hesperis matronalis*

Identification. Sweet rocket, also known as Dame's Rocket, is a member of the mustard family and is known by many names.

Often mistaken for Phlox, it's flowers have four petals, while Phlox flowers have five. The plant produces a mound of hairy foliage the first year and flowers in the second spring.

Edibility. Harvest sweet rocket before the plant flowers. Young leaves are best used as salad greens.

Seeds can be sprouted for micro-greens and used in salads.



As a Remedy. Harvest leaves while the plant is flowering and dry them for use as a diuretic and to induce perspiration. They are high in vitamin C and are useful in preventing scurvy.

Tobacco, *Nicotiana Tabacum*

Identification. Tobacco is an annual herbaceous plant of the Solanaceae family. Some *Nicotiana* species are cultivated as ornamentals, but most are grown for

⁴⁸ Photo by Gregory Phillips, CC-SA 3.0

tobacco leaf production. The plant grows to 4 feet tall and flowers from July to September.



49

Edibility. While protein extracts can be made from the leaves, it is highly toxic in its natural state, even in small amounts. All parts of the plant contain nicotine, which is the addictive substance in tobacco.

As a Remedy. Tobacco has a long history as a medicinal plant, commonly used as a relaxant. The

⁴⁹ Photo by Joachim Müllerchen, CC BY 2.5

leaves are used externally to treat skin diseases, scorpion stings and bug stings. Do not ingest the plant, it is an addictive narcotic and extremely toxic.

A homeopathic remedy made from dried leaves is used to treat nausea and motion sickness. The leaves are a diuretic, expectorant, irritant, narcotic, sedative and antispasmodic.

Violets, *Viola Papilionacea*



50

Identification. Violets are easily identified by the flowers and by their heart shaped leaves.

⁵⁰ Photo by Jörg Hempel, CC-SA 2.0

Edibility. The flowers and leaves both edible. The flowers are often used by chefs as a garnish for salads and cakes, and can be made into a tea or syrup. Similar to spinach in flavor, the leaves are used raw in salads or cooked as a green.

As a Remedy. Violets and their extracts have been used experimentally to treat tumors in mice, but no human trials have been done. The leaves and flowers are beneficial as an expectorant to treat coughs, colds and bronchitis.

A tea made from the leaves is beneficial for insomnia and as a laxative.

Violet leaves have also been reported to have antiseptic and pain relieving effects. Use a tea or compress to relieve headaches and neck pain.

Use in a poultice or in ointment form to relieve symptoms and heal wounds, sores and skin problems.

Walnuts, Juglans

Identification. Walnut trees are deciduous, growing up to 130 feet tall, with pinnate leaves in clusters of 5 to 25 leaflets. Leaves and blossoms appear in the mid-spring and the nuts ripen in the fall.



51

Edibility. The nuts of the walnut tree are edible and considered a good source of healthy oils and protein. Walnuts can be pickled in vinegar while still green in their husks or allowed to ripen on the tree and eaten shelled as a nut. Store the nuts in a cool, dry place to prevent mold and spoilage. The leaves can be used to make tea, and the sap can be tapped in the spring to make syrup or sugar.

As a Remedy. Walnut leaves are used internally to purify the blood and to treat constipation, stomach upsets, nausea, diarrhea, coughs, and asthma.

⁵¹ Photo by Böhringer Friedrich, CC-SA 2.5

The nuts and leaves are also used externally to treat skin diseases, eczema, wounds, and sores.

The walnuts are diuretic and a stimulant, and have been used to treat urination problems, back pain, and weakness in the legs.

Oil from the seed is used to treat dry skin and to treat parasitic worms.

Watercress, Nasturtium officinale

Identification. Watercress, a member of the Brassicaceae is a rapidly growing aquatic perennial with a spicy flavor. The stems are hollow and allow the plant to float. If left to grow, it can reach a height of 4 feet. Despite the botanical name, watercress is not to be confused with the nasturtium flowers.

Edibility. Use the leaves and stems raw in salads, sandwiches and in soups. Sprout the seeds for their edible shoots.

The leaves are best harvested before the plant begins to flower and the foliage turns bitter. Caution: Watercress grown where manure is present can host parasites, so look for plants grown in clean water.



52

As a Remedy. Watercress is used to treat respiratory illnesses such as coughs, colds, bronchitis, runny nose, sore throat and fevers. It has diuretic properties that help reduce edema and lower blood pressure. It has also been used historically to treat metabolic diseases, purify the blood and as a general tonic.

White Mustard, *Sinapis alba*

Identification. White mustard is an annual that grows over 2 feet high with pinnate leaves. It blooms in the early spring, producing hairy seed pods. White

⁵² Photo by Masparasol, CC 3.0

THE LOST WAYS II

mustard seeds are hard, round seeds, growing approximately 6 to a pod.



53

Edibility. The seeds, flowers, and leaves are edible. Harvest the seeds as the pods just begin to ripen, before they burst. Use the seeds for pickling or grind them and mix with vinegar to make a mustard condiment. The leaves are edible as mustard greens.

As a Remedy. Mustard seeds are known to be antibacterial, antifungal, an expectorant and diuretic. It mostly used externally as a poultice or added to bath water to treat coughs, tuberculosis and pleurisy. The

⁵³ Photo by SuperJew – Own Work, CC 3.0

seeds are an irritant to the mucous membranes and the skin, so dilute it and use it carefully.

Wild Black Cherry, *Prunus serotina*



Identification. Wild Black Cherry trees, also known as rum cherry, black cherry, or mountain black cherry, grow to 50 to 80 feet. It has dark gray bark with a reddish inner bark. The leaves are lance-shaped with toothed margins. The small white flowers appear from April to June. Each flower has 5 petals and grows in bunches of several dozen flowers.

⁵⁴ Photo by Botteville – Own Work

Edibility. The edible cherries are reddish-black when ripe. Eat only ripe fruit, but do not eat the overripe fruit on the ground and cook all fruit before eating. The taste is sharper than sweet cherries, but appealing. Use the fruit to make jam, pies, pastries and as a flavoring.

As a Remedy. Steep the bark in hot water, but do not boil. Use it to treat coughs, fevers, colds, flu, whooping cough, bronchial spasms, bronchitis, pneumonia, asthma, laryngitis and sore throats. It is also used to treat high blood pressure and poor circulation, relieve inflammation and reduce edema.

Wild Leeks, *Allium tricoccum*

Identification. Wild leeks, also known as ramps, spring onion, wood leek and wild garlic, are a perennial plant with broad leaves and a white bulb at ground level. They grow in closely packed groups and smell like onions and garlic with a flavor to match. Wild leeks look similar to the poisonous Lily -of-the-Valley, so be sure of your identification.

Edibility. Collect wild leeks in the early spring, taking only what you need and leaving the rest to replenish the supply. Eat the leaves and bulbs in salads or cooked. In many places, the harvesting of wild leeks is limited by law, so check your local laws before picking.



55

As a Remedy. Use wild leeks in the same way you would use garlic or onion for colds, croup and as a spring tonic. The warm juice of the leaves and bulbs is used for earaches.

Wild Potato-Vine, *Ipomoea Pandurata*

Identification. An Herbaceous perennial, the wild potato-vine grows in woodland areas. It is also known as man of the earth, wild potato vine, manroot, wild sweet potato, and wild rhubarb and produces white

⁵⁵ Photo by M, CCO 1.0, Public Domain

THE LOST WAYS II

funnel-shaped flowers (morning-glory) with a reddish-purple throat. The thin, heart-shaped leaves are 3 to 6 inches long. Unlike other morning-glories, it has ridged sepals and an enlarged root that can grow to be several feet long, 5 inches in diameter, and weigh up to 30 pounds.



56

Edibility. The large tuber is used as a food source or as a medicinal. Roast it to eat like a potato.

As a Remedy. Use the cooked root to prepare a pain-relieving poultice for aching joints. Raw roots are used sparingly as an expectorant, diuretic and laxative.

⁵⁶ Photo By KevinTernes at English Wikipedia - Own work, CC BY-SA 3.0

Wild Plum, *Prunus americana*



57

Identification. The perennial wild plum grows as a large bush or small tree, up to 25 feet tall. It is also known as American plum or yellow sweet plum. The tree spreads through the roots, creating groups of the thorny bushes. The alternate leaves are simple and oval or oblong in shape. They are 3 to 4 inches long and pointed at the tip. Fragrant flowers appear before or with the first leaves in the spring. Fruits are small, approximately 1 inch in diameter, with a single rounded pit.

Edibility. Look for ripe plums in the fall. The fruit is yellow-red to red when ripe. The fruit is sweet and

⁵⁷ Photo by Andrew Ciscel, CC – SA 2.0

sour, suitable for eating fresh or making preserves, jelly, jam and wine. It can also be dried for later use.

As a Remedy. The bark of wild plum has been used to treat coughs, and to make a tea that treats kidney and bladder infections.

Wild Yam, *Dioscorea Villosa*

Identification. The wild yam, also known as colic-root, Rheumatism root, and Devil's-bones, is a climbing vine common in the eastern United States.



58

⁵⁸ Photo by Phyzome assumed (based on copyright claims), CC BY-SA 3.0

It grows in damp locations, including swamps, thickets, damp woods and near ditches. It has a smooth, reddish-brown stem and heart-shaped leaves with prominent veins running from the top center of the heart to the edges in a fan pattern. The long, branched root is woody and forms tubers with a brown skin and white, fibrous center.

Edibility. The tubers are edible, although bland. Gather them in the fall and cook them with seasoning to improve the flavor.

As a Remedy. The tubers of wild yam contain chemicals similar to progesterone, estrogen and steroids used as contraceptives. Components of the plant are used in the chemical manufacture of hormones. A decoction of the root is often used as a natural hormone therapy for PMS, menstrual cramps, symptoms of menopause, and for increasing sexual drive and energy in both men and women. It also has anti-inflammatory and anti-spasmodic properties and acts as a vaso-dilator.

Wintergreen, *Gaultheria procumbens*

Identification. The American Wintergreen is the shrub originally responsible for the wintergreen flavor used

THE LOST WAYS II

in chewing gum, mouthwashes, toothpaste, candies and other mint flavored foods. Stems of the shrub creep along the soil and send up branches 2 to 6 inches tall. The alternate, oval leaves are leathery with serrated edges. The leaves and the bell-shaped flowers grow near the top of the branches. Flowers appear from spring through summer, with berrylike fruit following. The plant has the taste and scent of wintergreen.



59

Edibility. The berries and leaves are edible in moderation and are mostly used as a flavoring

As a Remedy. American wintergreen is used medicinally for various aches, pains and fever. The leaves contain methyl salicylate which metabolizes into salicylic acid, also known as aspirin. They can also be used as a tea.

⁵⁹ Photo by Mike Serfas, Public Domain

Wintergreen has been used as a poultice to stop bleeding, and to treat dog bites, snakebites, insect bites and other sores and wounds. It is an analgesic, diuretic, antiseptic, anti-spasmodic and anti-rheumatic.

Witch Hazel, *Hamamelis Virginiana*



Identification. Witch hazels, also known as winterbloom, are deciduous shrubs growing to 40 feet tall, with most under 25 feet tall. Alternating oval leaves are 2 to 6 inches long and 1 to 4 inches across. The current year's flowers bloom as the previous year's fruit matures.

Edibility. The plant is potentially toxic and should not be eaten.

As a Remedy. The leaves and bark are used to produce the astringent decoction used externally in herbal medicine and skin care products. It is commonly used as a herbal remedy to treat diaper rash, sores, bruises, psoriasis, eczema, poison ivy, bug bites, and burns. It is also used to reduce swelling, especially after childbirth.

A tea made from the leaves and bark has been used topically for hemorrhoids and ulcers. It can also be used as a gargle for a sore throat and as a rinse for mouth sores.

Wood Sorrel, *Oxalis*

Identification. Wood sorrel is an annual or perennial that grows to be approximately 3 inches high. The species is sometimes called false shamrocks for its arrangement of 3 heart-shaped leaves that are similar to clover. The white, pink, red or yellow flowers have 5 petals and 10 stamens.

Edibility. Wood sorrel is a commonly used food. The roots are starchy and taste similar to a potato when boiled. The leaves and stems are edible raw or cooked and can be chewed to alleviate thirst. The lemony-tasting leaves can be dried to make a tasty tea. The leaves contain oxalic acid and should be cooked if they are eaten in large quantities or on a regular basis.



60

As a Remedy. Wood sorrel has been used as an aphrodisiac and as a treat for fever, cramps, nausea, mouth sores and sore throats. The leaves are high in vitamin C and can be used to prevent scurvy.

Yaupon, Ilex vomitoria

Identification. Yaupon holly, also known as cassina, is an evergreen shrub commonly used as an ornamental plant in the southeastern United States. The mature plant stands 16 to 30 feet tall, with smooth, gray bark and thin, hairy shoots. Alternate leaves are dark green and glossy on top and lighter in color on the underside.

⁶⁰ Photo by KENPEI, CC-SA 3.0

THE LOST WAYS II

The fruit are small red or yellow berries containing 4 pits each.



Edibility. The leaves are used to brew a black tea that contains caffeine and theobromine. It can be used as an acceptable coffee substitute. The fruit is poisonous.

As a Remedy. A thick decoction of the leaves induces vomiting.

Yellow Birch, *Betula alleghaniensis*

Identification. It is also known as golden birch. Identifiable by its golden-bronze exfoliating bark and the wintergreen scent of a scraped twig, the yellow birch is a valuable survival plant of the eastern United States.



61

Edibility. The inner bark, sap, young twigs, and leaves are all edible. The inner bark can be eaten cooked. Dried and ground into a powder, it can be substituted for some of the flour in baked goods. Tea can be made by steeping the twigs and inner bark. Harvest the sap in early spring to use as a drink, concentrate it into a syrup, or ferment it into a beer.

As a Remedy. The plant is rarely used as a medicinal, although a decoction of the bark has been used as a blood purifier.

⁶¹ Photo by Keith Kanoti, CC 3.0

Yellow Rocket, *Barbarea*



Identification. Yellow rocket, also known as winter cress, American cress, Belle Isle cress and Scurvy cress, grows along rivers, streams, creeks and other wet areas. It is a perennial, growing up to 1 foot in height.

Edibility. Harvest the leaves when young and eat them raw or lightly cooked. Older leaves can be eaten, but they are strongly bitter. Cook them in several changes of water to reduce the bitterness. Unopened flower heads can be steamed like broccoli.

THE LOST WAYS II

As a Remedy. The leaves of yellow rocket are used to make a poultice for treating wounds. Use the leaves to make a tea with diuretic properties.

HOW TO PRESERVE HALF A PIG FOR A YEAR WITHOUT REFRIGERATION

- By Aaron -

*“Circumstances can force
your hand. So think ahead!”*

- Robert A. Heinlein

The techniques our forefathers used were simple and practical. I'm going to show you a curing recipe that I've learned from my grandfather, who learned it from his father and so on.

Curing the Meat

Get your meat ready. I will be curing approximately half a pig and a whole rabbit, but it can be done with any kind of meat, a large amount of salt, and a container. Make sure the meat is as fresh as possible!

THE LOST WAYS II



Pour around 3/4 to 1 inch of salt onto the bottom of the container, and place the pieces of meat inside one by one. Make sure to rub the salt into the meat as much as you can. You can also add more salt to the mixture, but don't overdo it.



THE LOST WAYS II

The meat must be brought to a fairly cool place in order for it to cure; the ideal temperature is 43–46.5°F. Because of this, the process is ideal in winter or fall, when the temperature is lower.



Let the meat sit inside the container with the salt for a few days. After one to two days have gone by, the meat will start leaking juices. Using this juice, wash the meat free of the salt, and then salt it once more until you can barely see the meat.

Flip it twice a day for two weeks then remove it and wash it off with its own juices once more. Then grab an egg from the fridge since you will need it for the next step.



Making the Curing Broth and Letting the Meat Rest

Next make a broth as this will cure the meat and give it the proper taste.

Ingredients:

- 4 gallons of water
- 2 ounces of garlic
- 13 bay leaves
- 15 pieces of allspice
- 10 pieces of cloves
- 25 pieces of juniper berries or pine nuts
- 4 tbsp chili flakes

THE LOST WAYS II

- 1 tbsp Provence seasoning mix
- 4 tbsp powdered paprika
- a small onion
- 3 tbsp black pepper
- 1 teaspoon dried thyme
- 2/3 cup brown sugar (increases the effectiveness of the salt)
- 2 tbsp ground coriander

Put all the ingredients (except the onion and the garlic) into a pot, and boil them for half an hour to an hour.

After that, let the broth cool and add the finely cut garlic, the onion slices, and the meat for curing.



THE LOST WAYS II

I mixed in the juices from the meat for extra flavor and mixed it all thoroughly.

To test if your broth is perfect, you can use an ancient technique that involves the egg you got out earlier.

The perfect salt level for the broth can be checked by placing the egg into the mixture; only half of the egg should be submerged inside it.

If you don't have a meat thermometer, three-fourths of the egg should be out of the water.



Place the meat in the broth, and leave it inside for two whole weeks.

THE LOST WAYS II



Make sure all of it is submerged under the mixture. I've built this contraption to make sure it stays down.



I've also turned the meat over every two days to make sure it is well mixed.

THE LOST WAYS II



After two weeks, they ended up looking like this:



After taking the pork out of the broth, I grabbed some of the leftover mixture and placed it into a bowl for the rabbit.

THE LOST WAYS II

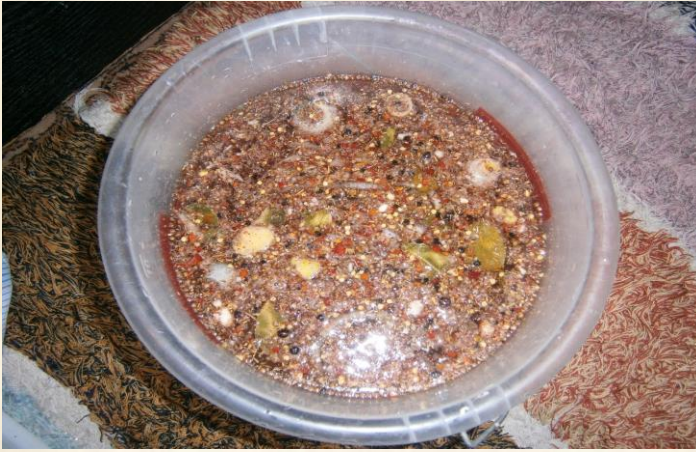

I put the rabbit into the mixture, but I could have just as easily used a duck or even a goose.



To keep it under the broth, I grabbed a plate, turned it upside down, and filled a jar with water to put on top of it.

THE LOST WAYS II

The difference in density between the water and the salty broth will make it float, but the weight of it will push it down just enough to keep the rabbit at the bottom. I let it rest inside the bowl for three days.



If you plan on the meat being preserved for a shorter period of time, one to two months, then you will need to make a new mixture for the meat that will be a 6% concentrated saltwater mix, strictly made with salt that doesn't contain any iodine.

Leave it inside this mixture for two days. (If you think that it might be too salty for you, you can leave it inside for another day, but then I'd recommend keeping it inside a fridge as the less salty the meat is, the less preserved it will be.)

THE LOST WAYS II



Once again, push it down so it's submerged completely. The concentration of the mix and the dense concentration inside the meat will get equalized until they are the same.



If you decide that you want a meat that will last up to a year without the need for a fridge or freezer, then

don't bother making this mixture or only leave it inside for 6–12 hours. Leave this meat inside a dry and well-aired place until you want to use it. For example, you could use an out of use furnace or a chilly storage room.

The meat from this will only be good for soups as its high salt concentration will not be good for eating it on its own. Before cooking, leave the meat in cold water for 12–24 hours, with three to four water changes; after this, it will be good for soups.

Warning: Even after letting the cold water soak up some of the salt concentration, the meat will most likely still have enough salt that you won't need to salt the soup.

If you made this kind of meat, then you're almost done. You've made a simple food that is perfect for a survival situation and will most likely be one of the best meat preservation techniques you will learn. Now you will only need to smoke the meat and you are ready to feast on your creation.

Preparing the Pork's Back Fat

If you have some pork back fat from the broth, it needs to be prepared another way to give it a pleasant taste when used. Take these and lay them out on a smooth

THE LOST WAYS II

surface. Leave these out to rest for a day so to dry up a little.



I prepared some garlic and water, mixed them together, and covered all sides of the fat, except the bottom side (the side with the skin).



THE LOST WAYS II

I covered them with paprika powder and rubbed them.



Then I covered the top until the fat wasn't visible anymore.



THE LOST WAYS II

After smoking the fat, we will get a super food that won't go bad during the hottest of summers, without refrigeration. It's an incredibly delicious treat in a slightly frozen form.

With a little bit of bread and some onion slices, you've got yourself a meal. But do watch out as this food hates diets. You can also unfreeze it and put it into different kinds of foods; it gives a wonderful smoky taste to any food.

Preparing the Meat for Smoking and the Process of Smoking

At this point, the meat's salt concentration has been lowered enough to take them out of the mixture and let them dry for 24 hours.



THE LOST WAYS II

After the meat has lost all of the mixtures that were still dripping off of it, you can prepare it for smoking.

For my smoking, I use two techniques to keep the meat above the smoke. I have hooks that can pierce the meat easily.



Or if you do not possess hooks like these or something similar, with the help of a few pieces of wood and few pieces of rope, you can solve your dilemma.

With a knife, cut holes into the meat where you want the meat to hang from.

THE LOST WAYS II



Tie a loop on a piece of twine, and insert it into the hole.



Put a piece of wood inside the loop and pull it tight. This way you have a hole to hang the meat from that can be accessed easily.

THE LOST WAYS II



With the pork leg, make two loops of twine and put them together; then put this around the leg and pull tightly to secure it.



Now it's time for the cold smoking!

THE LOST WAYS II



I used beech tree sawdust. I went for simplicity and just filled a metal container with sawdust then lit it up until I saw a little smoke.



Smoke the meat during the day, and let it rest at night. Continue this process for three to four days.

THE LOST WAYS II

If you decide you want to do the kind that can last for a year, leave it for five to six days.

This is what the finished meat looked like:



Put the meat into a cold and well-aired place for another week to set the taste in. Don't worry; you can have a bite of this superfood.

With this information, you can literally preserve any kind of meat you have in mind; the only difference would be if it's a thicker meat like the pork leg, which needs to sit inside the salt and then the broth for another seven days each.

HOW TO SHARPEN YOUR BLADES LIKE THE SAMURAI DID

- By James Walton -

*“The Samurai always has to rise and
move on, because new challenges
will come.”*

- Lyoto Machida

A dominant warrior class of noblemen who also held some of the highest ranks in Japanese leadership, the samurai are legendary. There may have never been nor will there ever be a ruling class like the samurai ever again. This is not to say they were great heroes of history. In fact, their rule was part of one of the great military dictatorships of all time and the largest in Japanese history.

The Samurai swords were always worn and were considered an extension of their sole. They carried two swords each. A long sword, called the *katana* and

THE LOST WAYS II

short sword called the *wakizashi*. The swords are known for being some of the sharpest of their time and the technique is praised even today. It requires more than just a sharpener. It also takes lots of time, effort and skill.

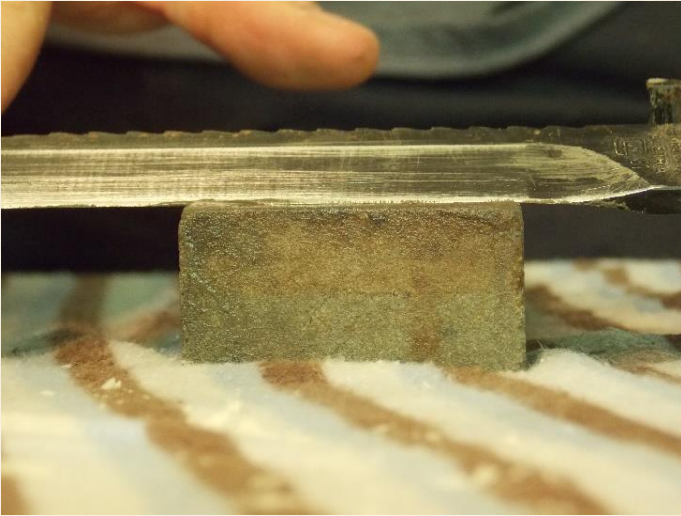

Though they are rarely credited for such skills, samurais were also great archers. This was a part of their skill set and they utilized bows made from bamboo. The arrows were crafted from bamboo as well. This really got my attention in terms of creating bows. I had never considered bows and arrows from bamboo.

The samurai were also effective on horseback and in the 13th Century they fought off two Mongol invasions.

This is a credit not just to the skill of the samurai but also to the resiliency.

Unfortunately, in the late 1800s the Samurai were abolished and the wearing of sword was forbidden soon after. It became a right for only active military personnel.

Of course, the traditions of the samurai live on in things like movies, jujitsu and other practices. We are going to discuss one such technique in this chapter. Though we do not carry swords today many of us have several blades in our EDC or fixed blade knives in our survival kits. These blades can be run across a sharpener to achieve a decent edge. I want to explore the process of sharpening like a samurai and creating a crafted razor edge.

The samurai sharpening kit:

- At least two whet stones of different grains (I use a double sided)
- A piece of high grit sandpaper
- Polishing oil or mineral oil
- A ball of wax



We are going to use a standard military issued, fixed blade knife. As you can see it needs some work.

The traditional samurai sword is usually fixed in jigs during the sharpening process. For such small blades, we are going to leave the stones stationary.

Soaking your stones

To use the wet stones properly you need to soak them for at least 20 minutes. This will allow the water to permeate. It will be this water and the coarse grain that allows the knife to slide easily over the stone. I like to pour some water directly on the stone as well for lubrication.

Get a Grip

Depending on the size of your blade and handle you may want to bolster your grip. This may seem important for large blades like katanas but it can also be very important when sharpening small blades. These knives usually have small handles that can be tough to bear down on. Don't slip and cut yourself!

Follow the Given Path

Before you begin sharpening you should observe the blade and take note of its natural curvature. Your movements over the stone must match the proper angle and follow the curve of the blade as well. Remember, any part of the blade that doesn't touch the stone will not be sharpened.



THE LOST WAYS II



Shitagi Togi



This is the first stage of sharpening and the coarsest stone you have should be used first. This is the portion of sharpening is for refining the once impressive shape of a worn blade. You can also use this coarse stone to remove any nicks and grooves.

100 Strokes

Work each stone for 100 strokes on each side of the blade. After you have done this move to the less coarse stone. It takes a lot to bring back the razor edge by hand.

Pay attention to each stroke and follow that natural path of the blade.

Shiaji Togi

This is the point when you will utilize the fine grit sandpaper to really bring out the tempering line. You will work the sandpaper back and forth to define this tempering line.

On smaller knives this will be a challenge and you should hold the sandpaper with a cloth so if the blade cuts through it doesn't cut you in the process.

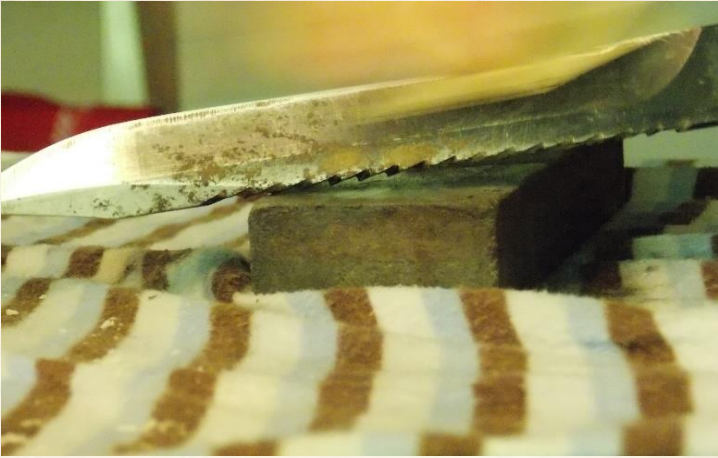

Polish

Use your sharpening oil and the residual grit from the process to polish the whole blade. My blade will require lots of polishing because it is pretty beat-up. You will see the payoff in the end.



Finish

Buff your blade with a ball of wax to finish the blade and wipe the entire knife down removing any residual dirt.

After some demanding work this blade was brought back from the dead. I am very happy with the blade achieved and the condition of the knife.

The look has improved from the polishing as well.



THE LOST WAYS II



Sharpening knives is one of those tasks that struggles against the tide of technology and time. Though, if you set aside the time to do an excellent job it's an entrancing and rewarding process.

THE LOST WAYS II

HOW TO WAX CHEESE

- By Aaron -

*“Knowledge is the key to survival,
the real beauty of that is that it
doesn't weigh anything.”*

- Ray Mears

Do you want to always have cheese on hand and not have to bother about going to the grocery store all the time? Well, waxing cheese is your answer because this is the best method to preserve it (and age it) for the long term.

In addition, wax protects the cheese from bacteria and mold. It also keeps it moisturized and reduces the time you have to spend working on the cheese.

Waxing cheese is the easiest and best thing you can do to take your love for making and aging cheese at home to the next level.

Ingredients

- ❖ Cheese (Ideally, permit the cheese to produce a bare, yellowish coating by being left unsealed on a stand in a cool area for some weeks.)
- ❖ Beeswax
- ❖ Honey to give the cheese an interesting taste. For 7 oz of cheese, I used a teaspoon of honey. (optional)



Melting the Wax

Melting the wax is as simple as melting any other material. You will just need a heat source and a pot (preferably an old one since cleaning it will prove to be quite difficult).

THE LOST WAYS II



Warning: Molten wax is flammable, so make sure you check it regularly during the melting process.



Adding the Honey (Optional)

After the resin has melted, you need to take it off the stove and add the honey. Stir the mixture for five

THE LOST WAYS II

minutes so the honey dissolves completely and incorporates into the wax.

After that, leave it to rest for another five minutes to cool down enough so that you can handle it.

You can speed up the process by stirring it.



Brushing the Cheese/Dipping the Cheese

Before you start doing any of it, you need to choose your method. You can brush the cheese, and this will result in a more even wax. It also requires smaller quantities of wax because you'll only need as much as the brush's length (to be dipped in).

THE LOST WAYS II



Or you can dip the cheese, which is my method of choice because it kills off any mold spores that might still be on the cheese while preventing any further mold from growing.

Another advantage is that you won't have to trouble yourself with cleaning up a brush, but you will need to be very cautious with the heated wax since it can easily burn your hand.



THE LOST WAYS II

Dip the cheese into the wax, and leave it to rest for three seconds; then rotate it to the other side.



After that, take the initial portion of cheese and cover the unwaxed end. One light coat is better than a dense layer.

Let the wax solidify on the cheese, and repeat the same with the other parts of the cheese. Be certain to fill any air scopes to inhibit mold germination.

I would recommend doing this with bare hands, even though there's a risk of burning your fingers.

It will give you a better grip when rotating the cheese.

THE LOST WAYS II

Repeat the above moves to join the second layer of wax to every part of the cheese.



And there you go—the finished product is done. Place it onto two glasses so it can dry faster.

The glasses are also necessary if you're brushing so that you have a good reach over the cheese, and I would recommend placing something (aluminum foil is best) under the glasses so you don't get the place messy.

THE LOST WAYS II



After that, I did the same with a round cheese. I dipped it into the wax and slowly turned it around so I could get the entire circle. If you're doing multiple pieces of cheese, you might need to put the wax back onto the stove for a few seconds. This way it will be hot enough for the dipping.



THE LOST WAYS II



After finishing up with this piece, place it onto the glass and let it sit for a few seconds; it cools off pretty fast, so you won't need to wait for long.

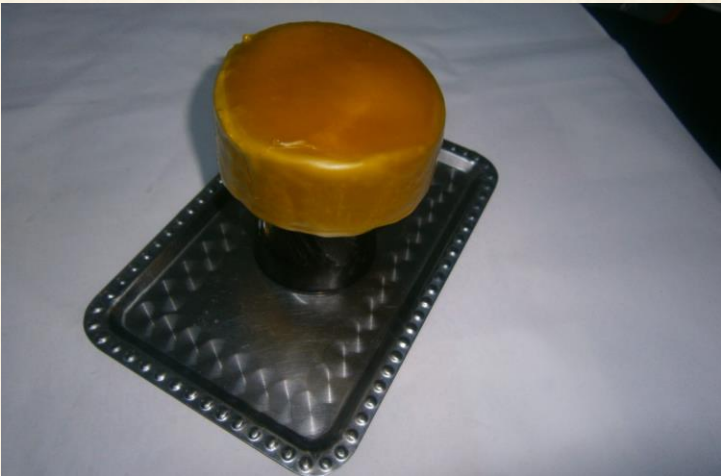

THE LOST WAYS II

Collect all the wax that was left, and store it to use it at any time.



When you start eating your waxed cheese, you can seal the remaining chunks with some melted wax.



Cheese waxing is an easy and quick way to protect your cheese from anything that would slow down the process of aging it. The entire process took me one to

two hours to complete, but it was worth it! Your cheese will age beautifully and safely.

Essential Reminders

- ❖ When you discern any holes in your cheese later, you can just go back and add more heated wax to those points.
- ❖ The wax is always reusable. Therefore, you can eat your cheese and then learn how to preserve the wax for later purposes.
- ❖ Whenever you free your cheese and see spots of mold wherever the wax fractured and air leaked inside, simply chop off the ruined area. The remainder of the cheese will always be exquisite.
- ❖ Cheese will age over a season, so do not be shocked when your cheese tastes strange when you save it for an extended period. It should taste even better!
- ❖ You may also pre-cover your cheese using a cheese cloth. It difficult to use the already waxed cheese later since it was difficult to tear off a single sheet of the cheese cloth. I always put the wax on every bit of the cheese that we are not utilizing and seal up the free end using the wax of the pieces we used.

THE LOST WAYS II

That is all there is to it! It is truly a relaxing routine and will make you feel great knowing that you have a great stock of cheese available and waiting for you!



HOW TO BUILD A LOG CABIN LIKE THE EARLY SETTLERS OF NORTH AMERICA

-By John Paicu-

*“The civilized man has built a
coach, but has lost the use of
his feet.”*

- Ralph Waldo Emerson

Even though the origins of the log cabin are uncertain, historians claim that these simple yet sturdy structures originated with the earliest settlers to the Americas, from Northern Europe, in the Bronze Age (sometime around 3500 BC).

When the first Europeans set foot on American soil, they already knew how to build cabins and barns from logs.

THE LOST WAYS II



Figure 1. Log cabin with round-shaped logs

In most Scandinavian countries, the land was covered with softwood timber that was very easy to work with.

Carpenters and woodworkers would use basic handmade tools to cut down and prepare the trees for the construction.



Figure 2. Round-shaped logs on a stone foundation

The Finns, in particular, would build their log cabins using different construction techniques. Some used round logs for their cabins [Figure 2.], while others would hew their logs into square-shaped or round-shaped

THE LOST WAYS II

logs to give their homes a finished, more appealing look.

When the Swedes and Finns first arrived in New Sweden —on the Delaware River—they brought their construction techniques and wood craftsmanship with them. Their first settlements were in Delaware, Pennsylvania, New Jersey, and Maryland. Even today these regions have the oldest and most representative types of traditional log cabins.

Since it would have been very difficult for early settlers and pioneers to carry building materials with them across the ocean, rivers, and mountain valleys, they would make their own tools upon arrival. The basic tools used to build a log cabin are presented below:



Figure 4. Mallet



Figure 5. Slick



Figure 3. Chisel

THE LOST WAYS II



Figure 7. Broad axe

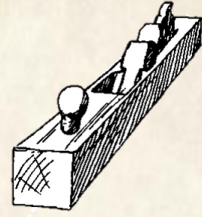

Figure 6. Jack plane

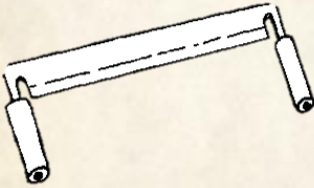

Figure 8. Drawknife



Figure 9. Auger



Figure 11. Adze

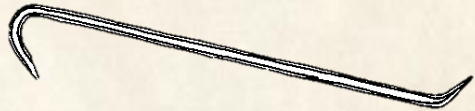

Figure 10. Pry bar

THE LOST WAYS II

The most forested areas were preferred sites for an initial dwelling. They didn't use spikes or nails when fitting the logs but rather notches and dowels made of logs. Building a log cabin was relatively easy. After cutting and trimming the trees in mid-winter [Figure 13], they would drag them to the construction site, peel them [Figure 14], and then wait until spring to be able to start the cabin's construction.

For this guide, we will use a basic log cabin plan [Figure 12]:

- One space (kitchen + living area)
- Bedroom: 8'5" in width and 25' in length
- Bath: 11' in length and 6'5" in width

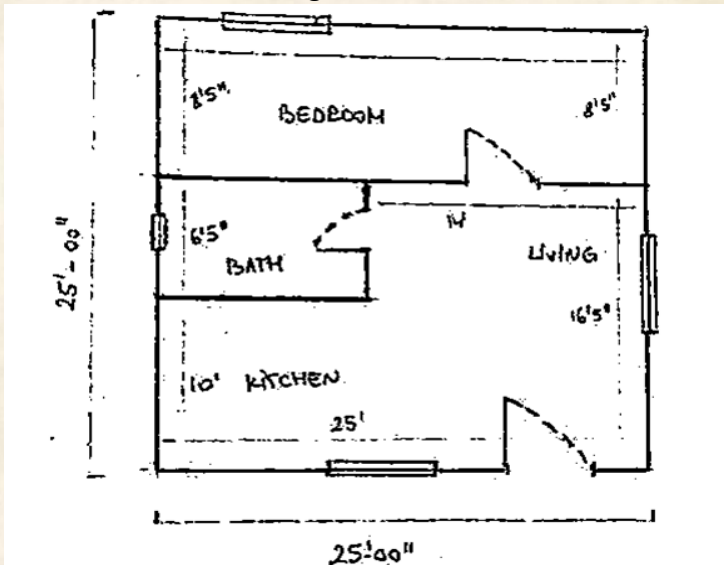

Figure 12. Log cabin

THE LOST WAYS II

The overall size of the cabin's walls is 25' in length and 25' in width. However, yours might have an additional overall length and width with a few inches (about 20), depending on how thick the logs are.

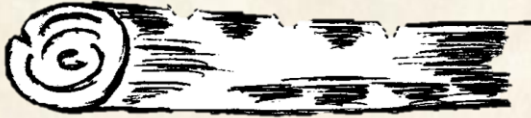

Figure 13. Crisscrosses to prepare the tree for peeling

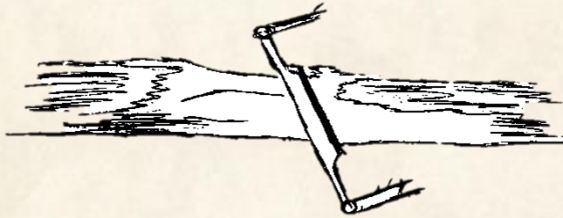

Figure 14. Peeling with a drawknife

In order to build the cabin, the logs had to be perfectly dry. The structures were extremely simple, and most of them had one room, called a "pen," with a fireplace and chimney placed at one of the cabin's ends. The chimney was made of wattle, and for the hearth, they would use clay or stone.

THE LOST WAYS II

The fireplace [Figure 15] should be constructed from fire-bricks, and you can use ordinary bricks for the chimney. If you prefer a chimney made of stone, make sure that there is a fire-brick lining for your fireplace. It is



Figure 15. Fire-brick

recommended to build

the fireplace over three feet in height and about three to five feet wide. A deep throat is best because it permits easy elimination of the smoke. The face of your fireplace can easily be made of stone or brick; you can use both materials if you'd like.

As for the opening, it might be a good idea to choose an arched opening or perhaps a stone lintel positioned across it to uphold the masonry work at the top. Above the opening of the fireplace, build ledges on which to place the mantel shelf.

THE LOST WAYS II

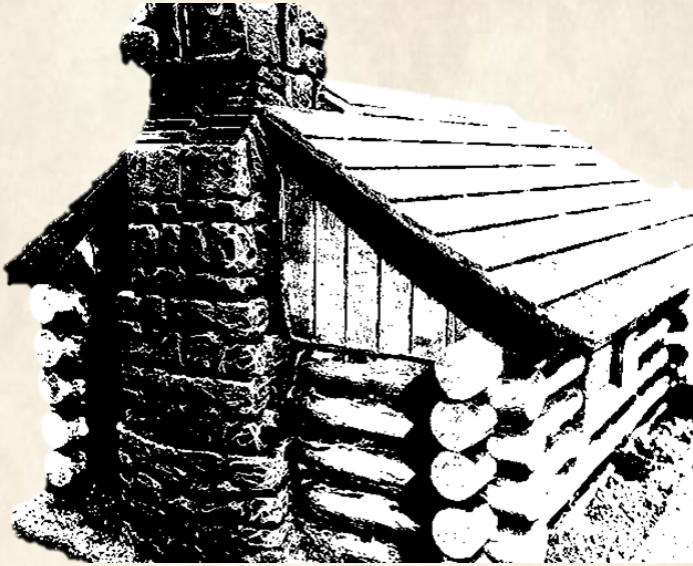

Figure 16. Basic square-shaped log cabin fireplace

Back in the 17th and 18th centuries, log cabins had a basic square shape [Figure 16] measuring approximately 19 feet long (on all four sides) and about nine feet in height. Traditional log cabins were made of simple stone foundations [Figure 17].

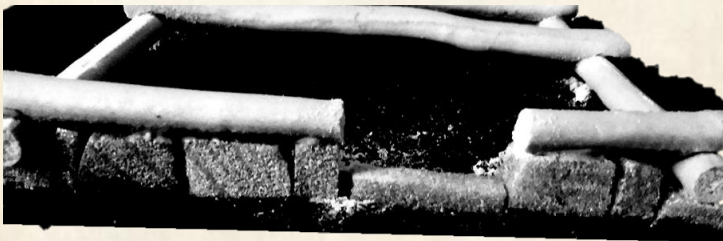

Figure 17. Stone foundation

THE LOST WAYS II

If you decide to use stone for your foundation, make sure to dig holes at least three feet in depth and about two feet in diameter. These holes must be filled with smaller-sized stones until you reach ground level. The next step is to install larger cobblestones. Place them on top of smaller-sized stones, and make sure they fit properly into place.

On top of the stone foundation, woodworkers would place the sills—basically the four straightest and sturdiest logs. To seal the cabin and prevent outside elements from entering the structure, they would use tar oakum to isolate the holes and extra space between the stone foundation and the logs [Figure 18].



Figure 18. Stone foundation, tar oakum & moss with sill

When building in height, the logs had to be notched at the bottom and at the corners to ensure proper fitting. Several techniques were used, although in Figure 19, we've detailed the lock notch. Other forms of notching

THE LOST WAYS II

[Figure 20] include the dovetail, saddle, and lap joint notch.

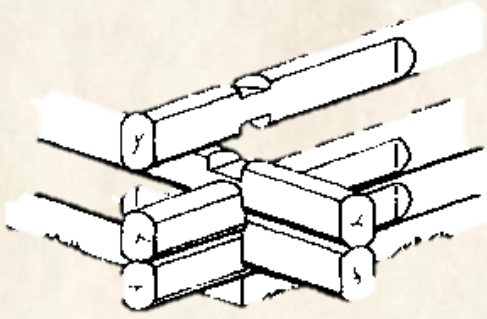

Figure 19. Lock notching



Figure 20. Log notching on round-shaped logs

On the inside, a traditional log cabin is rather small, with just one or two rooms. The most spacious room was the kitchen, which often was used for eating,

THE LOST WAYS II

cooking, and even sleeping. The fireplace had a very important role too. It was meant to be the stove as well as the main heating source for the entire structure.

Preparing the Logs & Settling the Foundation

Before settling the stone foundation, early settlers would first prepare the logs. After cutting them down in mid-winter, they would peel them with a drawknife [Figure 14] to ensure even dehydration and then place them off the ground in crisscross piles to prevent moisture absorption. Then they would wait until spring before starting the construction.

For this guide, we will use a stone foundation, just like the pioneers did back in the 18th century. The stones must be about 1.5 feet in length and 1 foot in height.

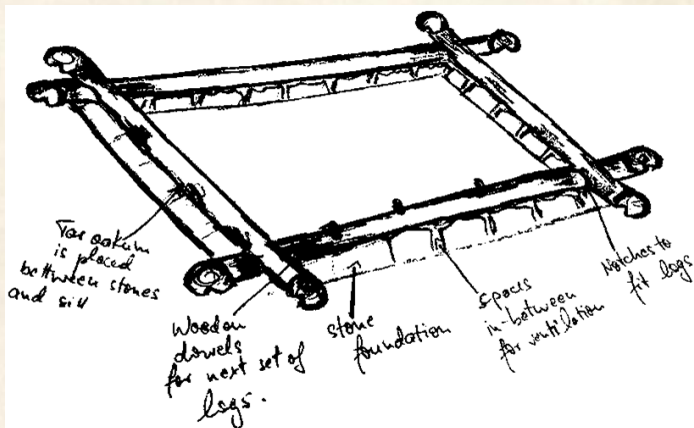

Figure 21. Stone foundation & sill

THE LOST WAYS II

Make sure the top base of the stones is as straight as possible to be able to place the sills evenly later on. There has to be a small space between each stone for proper ventilation.

After you've made the stone foundation, make sure the stones are placed properly under the ground, just above frost level. You should place the sill on top of the stone foundation. Choose four of your longest, thickest, and straightest logs [Figure 22].



Figure 22. Stone foundation & V-shaped log

The sill is very important because it will hold the rest of the cabin. Before placing the first set of logs, use tar oakum to seal the space between the stones and the sill to make sure your cabin is properly insulated [Figure 21]. To make sure that the logs fit properly, they have to be carved at the bottom and at the corners.

THE LOST WAYS II

There are several notching techniques that constructors use: V-notch, saddle notch, dovetail and half dovetail notch, and square notch. The main purpose of notching the logs is to improve tightness at the corners. Tar oakum is used once again for insulation.

The first set of logs (the sill) is caved at the bottom to fit the stone foundation. Two of the logs are notched at the top to ensure perfect fitting crosswise of the sill. Moss and tar oakum are placed in between to seal the logs.

After the first set of logs has been placed, fitted, and sealed, carpenters would have to drill holes (about 1.5") in the logs with an auger. Then they would drill dowels [Figure 23], place some more tar oakum, carve a second set of logs on the bottom, and place these on top of the sill.

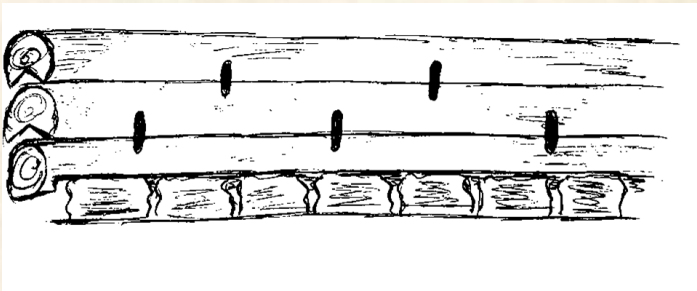

Figure 23. Dowels in between logs for stability

Building the walls, door & windows

With the same auger, holes are drilled to prepare the doors and windows. About 12–14 logs are needed to complete one wall of a 25-foot long cabin. The height between the foundation and the top end of a wall should be about 10 feet, with each log being 14 inches in thickness.

The easiest way to frame the doors and windows is by notching the ends of the logs surrounding the doors and windows [Figure 24.]. Then you need to place pre-made breads into place for proper framing. There has to be space between the window frames and log boards (about one inch) to define the windows. Fastening can be done with wedges.

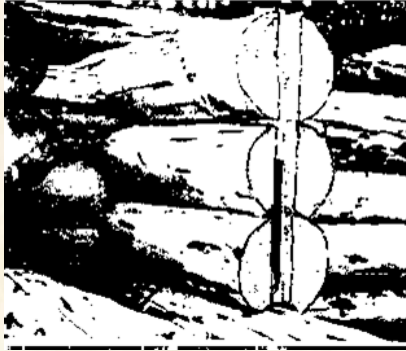

Figure 24. Log notching to frame door and windows



Figure 25. Window framing

To verify that the frames are aligned correctly, use a bubble level tool. Then feel free to install the hinged and glazed frames. Fill in the space between the log boards and window frames with as much tar oakum as you can fit in it, and then seal the windows with wide log boards [Figure 25].

Inside Flooring

A log cabin built back in the 18th century would sit on plain dirt. This means proper insulation on the inside is fundamental in order to keep the floor dry. The pioneers would use birch bark on the ground before placing the logs that separated the rooms to define the floor base. To preserve ventilation, you can create channels with tiles and rocks. Once again, the logs must be notched at the corners and fitted [Figure 26]. These supporting beams are placed about 20 inches apart, and they need to be crisscrossed until you have square shapes all around the cabin.

THE LOST WAYS II

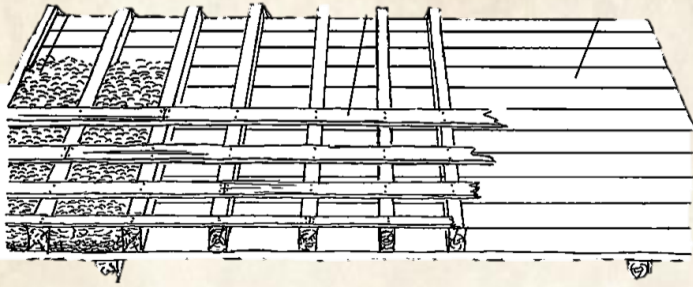

Figure 26. Dirt flooring

Each square has an average diameter or 20" x 20". However, the squares near the walls will be narrower—about 5". The pioneers used dirt to fill the holes at the margins, and they would leave the middle empty for proper ventilation, coolness, and even extra storage. The next step is to install the floor boards. Back in the day, the pioneers didn't have nails or any other adhesive to connect the planks. They would use dowels to fasten them together [Figure 27].

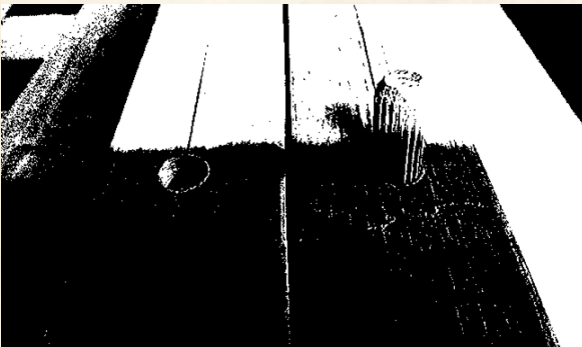

Figure 27. Wood planks fastened with wooden dowels

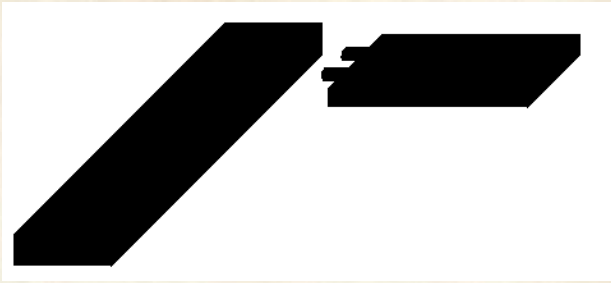

Figure 28. Installing floor boards

At the corners—where the floor meets the walls—a top layer of planks is installed using nails to insulate the floor. At the entrance, the small hallway's floor is filled with sawdust. Then narrow wood planks are placed on top and fastened with dowels.

The exact type of wood planks used for the floor is also used for the ceiling [Figure 28]. However, they're not fastened with dowels but rather overlapped and nailed (a technique called shiplap [Figure 30]).



Figure 29. Shiplapped ceiling

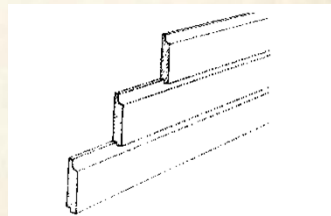

Figure 30. Shiplapping ceiling planks

Before placing the planks on the ceiling, the boards are carved. A rabbeted joint is made at the edges to fit the pieces together and increase stability [Figure 29]. Tar paper and sawdust is poured to insulate the ceiling.



Figure 31. Log cabin front door

A traditional door for a log cabin is also made of wood planks [Figure 31]. Once again, the space between the frame and the door hinges has to be sealed with tar oakum and weatherboards, both on the inside and outside.

The Roof

Before starting the roof, one must settle on a roof height and build the gable or roof pitch (which is also made from logs). After the gable is complete, notch it to the last log you used for the walls. Then give your cabin a nice finish by cutting the excess wood off. This technique will also frame the roof and give it a perfect triangular shape.

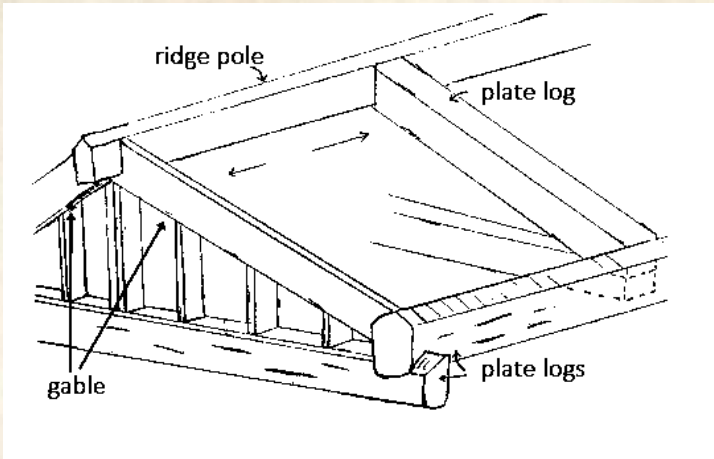

Figure 32. Roof truss: gable, ridge pole & plate logs

There are different ways to build the roof on a log cabin. For this guide, we'll also mention plate logs, purlins (or rafters), and the main ridge pole [Figure 32]. Together, these elements form the cabin's truss. All elements should also be made of thick, sturdy logs to hold the rest of the materials included in the making of the roof.

The purlins are notched and cut into the ends of the gable. However, some woodworkers don't use purlins but stick to rafters. As soon as the rafters or purlins have been installed, you can start placing the roofing boards (joists) to cover the roof [Figure 33].

THE LOST WAYS II

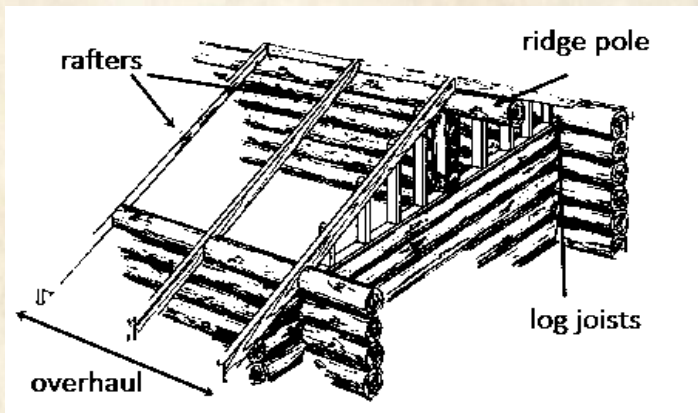

Figure 33. Cabin roof joists & overhaul

If you don't have a log that's long enough for the ridge pole, you can use two logs joined together with a hook notch. The roof's truss and main structure is very simple; however, the logs must be notched and fitted perfectly to guarantee stability and sturdiness. Basically, the whole roof depends on the ridge beam, ceiling joists, and under-purlins. The walls play a fundamental role too. The last four logs used to build the walls are also meant to support it. This means they need to be thick, straight, and notched in between to fit the roof.

After the roof has been properly fitted, horizontal joists made of plate logs [Figure 34] are used to frame the ceiling. These must be aligned with the ceiling joists.



Figure 34. Roof boards for coverage

Then rafters are used to cover the truss and give the cabin a triangular shape. As rafters are placed, an overhaul has to be created at the end of the roof, where the top walls meet the ceiling [Figure 36]. This is to make sure that when it rains, the water is drained properly so that no moisture infiltrates into the walls and ceiling.

The logs used to fill up the front of the roof must be carved to frame the truss [Figure 35]. To ensure that the ridge beam is stable and fitted to the truss, dowels are drilled both in the front and at the end of the roof's edges.



Figure 35. Truss framing

Before finishing off the roof, all walls must be hewed, both on the inside and outside. Hewing is an extremely meticulous endeavor, and only the most experienced carpenters can do it properly. Basically, hewing gives the cabin a nice, uniform look, and the finish is done using a broad-axe.

Following the hewing process, you can move on to installing the rafters from the overhaul up [Figure 36]. The first rafter is called the “drip board,” and it usually extends a few inches out of the cabin’s walls, marking the overhaul. Considering the technique used to build the cabin involves placing one log on top of the other using notches, it’s natural for the corners to be more

THE LOST WAYS II

prominent. You can leave those out or cut them to give your cabin a perfect square shape.

After properly fitting all rafters, the next step is to install the roof shingles. Before placing shingles, a line board is set into place [Figure 36], about one inch over the “drip board.” The first set of shingles is shorter than the others. If you decide on shingles that are 17” in length and 5” in width for the roof, the first set that goes after the line board should be one-third of that length.

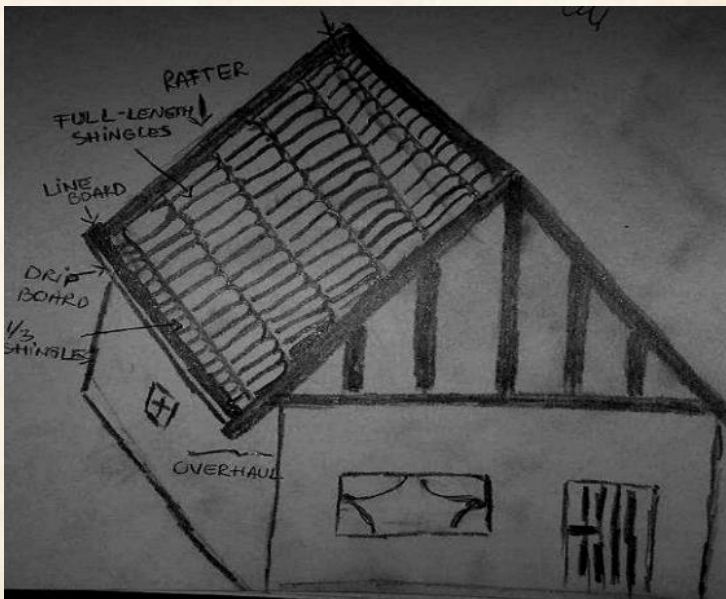

Figure 36. Log cabin roof

THE LOST WAYS II

Overlapping the shingles [Figure 37] must be done very carefully. After the first round has been properly installed and nailed, a second set made of full-length shingles comes next. The number of layers placed usually depends on the height of your roof. Close to the ridge beam, short shingles are used once again. Side boards are used at the ends to frame the roof and protect the shingles. A ridge board is used to cover the ridge beam and connect the singles coming from the right and left sides of the roof.



Figure 37. Roof shingles

The pioneers were famous for their long-lasting log cabins. The tools, techniques, and basic materials used have been inspiring modern builders for centuries. Nowadays, even though we have modern materials

and new equipment we can use to ease the process, the methods used centuries ago are still being used today. The only difference is that they've been adapted to make the process less painstaking.

A Case Study: How I Built My Log Cabin Following the Pioneer Method Using Modern Tools

- By Kaylee Price -

Ever since I can remember, I've been fascinated with how our forefathers lived. I purchased *The Lost Ways* several months ago, and I decided I would try to make a small project every month. In the course of the next three months, I made pemmican, soap, and hardtack. I enjoyed the process and the results so much that I decided to embark on a bigger journey: making my own log cabin. I simply wanted a peaceful retreat where I could spend my holidays, away from crowded highways and in the middle of the woods.

What I didn't know at that time is that although I will enjoy the cabin all summer long, I enjoyed building it

THE LOST WAYS II

even more. For my boyfriend and I, it was a peaceful way to find a simple way of life.

Unfortunately, no pre-made log cabin plans will be exactly right for you. I realized that in order to build your dream cabin, you need to make your own changes. In my case, I wanted to have one more story than the cabin plans I found in *The Lost Ways 2*.

I did use a couple of modern tools and some new materials I already had as well as some that were cheaper than what they used 300 years ago.

There is no experience like actually building a log cabin with your own hands. It's an experience in and of itself since you're basically building it similar to how they did it decades ago. Every little detail counts when building a log cabin from scratch. But the result is amazing. Unlike an already existing house, you're connected to it.

There are many steps we took to build our log cabin. First came picking the perfect spot, which was easy. The size of 22' by 20' was decided upon, so we measured it out on the ground with the longer side being against the ditch then marked the ground with spray paint so it would fit the length and width we

THE LOST WAYS II

wanted. After looking over the placement, we made the final decision that we wanted to put it there.



Choosing the right logs on our lot came next. We had to find over one hundred trees that were suitable for stacking to make the walls.

The logs had to be at least twenty-five feet long with the smallest end being no smaller than the palm of your hand. We cut down all of the trees using chainsaws, wedges, and an ax. Every once in a while, we had to tie a rope to the tree and pull it with the four-wheeler so it would fall in the direction we wanted it to.

After cutting the trees down, we had to delimb them with chainsaws. We cut them all to length and hauled them up to the house.

THE LOST WAYS II



Once the logs were moved up to the house, they had to be peeled using chisels, pocket knives, and draw knives before we could put them up. How dead the tree was determined how difficult it was to peel the logs, with fresh logs being the easiest to peel. It took us anywhere from fifteen to forty-five minutes just to peel one log. The worst part about peeling the logs was by far the tree sap. Every time we hit a sap bubble, it would spray us in the face.

Our next step after the logs were peeled was to start putting them in place. The logs had to be stacked in sets of two with the big ends of each log opposite each other.

Once we had enough logs to put down, we hauled them in place. The first two logs set on the ground, and the next two set on those. We had to use the chainsaw

THE LOST WAYS II

to cut notches in the logs so they wouldn't move. We put spikes in the notches before we put the next logs in place.



This process of lifting the logs and notching them was repeated until we couldn't do it by hand anymore.



After the cabin was too tall for us to lift the logs by hand, we had to use the winch on our four-wheeler to lift them up.

THE LOST WAYS II



THE LOST WAYS II



After we got the walls nine feet tall, we decided where we wanted to put the door. The door frame needed to be flat, so we put boards vertically on both sides of where we wanted it.

Then we measured the height and width of the door and cut the logs slightly bigger to fit it. We affixed the center of the logs by either screwing them in closer to the board or unscrewing them so their centers would line up.

THE LOST WAYS II



After we put the door in, our next step was to find logs that were appealing to the eye to use as support beams for the loft. For the support beams, we cut six of them to length and put them equal distances apart along the width of the cabin. For the floor of the loft, we put down boards that we had planed from trees on our property. We put up four more sets of logs after we put the loft in.

THE LOST WAYS II



In between the logs, we put a muddy clay mixture of chinking to seal the gaps. Chinking is made from sawdust, clay, ice salt, and water. This form of chinking has been used for decades. If we made the chinking too watery, it would be runny, and if it was too dry, it would be crumbly. We threw it in the cracks in between the logs and smoothed it over with mudding tools to make it more attractive.



THE LOST WAYS II



The next step was to make stairs to go up to the loft. The boards we used for the treads had to be at least 3" thick and identical lengths. When making stairs, you have to follow a formula of 7/11: 7 inches up and 11 inches back. We also had to put two long boards diagonal from the ground to the loft to connect the steps.

A 90-degree angle had to be cut at the top of each diagonal board to fit it onto the loft securely. The stairs had to be built away from the wall so we could connect the steps with lug bolts to hold them in place. After the steps were complete, we had to move the stairs over to the wall and secure them in place. When they were secured to the wall, we cut the excess off on the top to make the stairs flat.

THE LOST WAYS II



When it came time to construct the interior walls for the loft, we did not include logs; instead, we used lumber to make the walls and the roof. To begin, you

THE LOST WAYS II

need to make a straight line with a couple two by fours.



Next, you're going to need to find out what incline you want your roof to be at and then coordinate that with the slope you're making. The frame is comprised of support beams that connect the bottom of the wall and the roof and support beams every 16 inches.

When you complete the frame, you need to put plywood on it and nail it down to every beam. After you nail the plywood down, you need to cut out where the window goes.

Tyvek is the next step, and you have to layer it like you would shingles so rain doesn't get in. You cut the Tyvek off of the window, leaving a couple inches on each

THE LOST WAYS II

side; then you cut them at a diagonal from the corners so they can be folded over.



THE LOST WAYS II



The roof comes next. After you get the frame put up for the walls, you have to put your cross beam up. We “sistered” two boards together to form our cross beam, and then the roof spars had to be put in place. The roof spars connect from the bottom of the frame to the top, where the cross beam is at.

THE LOST WAYS II

The spars have to be cut at one or both ends for whatever angle you decided to do for your roof. Once you have all of them up and have spacers put in your next step would be to put the plywood up. We put a tarp over the plywood after we had it all nailed in place for a temporary roof.



THE LOST WAYS II



THE LOST WAYS II



Creating the floor in the downstairs was the last step to making the cabin livable. We needed to put two by sixes against the wall level where the floor was going. The reason for this is that when you put a floor in, you need a flat surface to work on, and the logs were round. A cross beam needed to be placed in the middle of the floor lengthwise with a concrete block under the center for support. Two by sixes had to be

THE LOST WAYS II

placed every eighteen inches from the wall to the center beam. Thick plastic was laid down before the plywood to form a moisture barrier. The plastic got stapled down then taped at the seams. Plywood went down next, starting in the corner; plywood has line markers on it to make it easier to nail it down. You just need to make sure the markers line up with your beams.

When we finished, we were in awe that we actually did it. We really built a log cabin. Looking back on everything, we did see a couple of the steps we would have done differently that would have made it a lot easier, but overall, we are very happy with the outcome. Building a log cabin was an experience that we learned a lot from. We will be doing it again....



THE LOST WAYS II

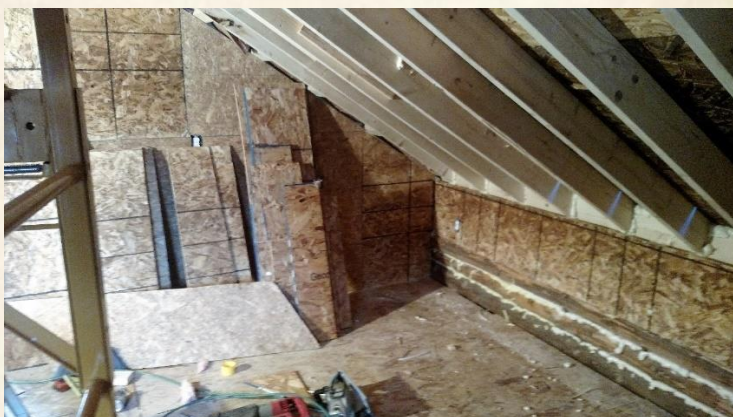

THE LOST WAYS II



HOW TO MAKE CHUÑOS, THE INCA SURVIVAL FOOD

- By Julie Danes -

“If you don’t prepare, you could lose everything. If you prepare for the worst and nothing happens, you’ve lost nothing.”

- Gerald Celente

The existence of chuño dates back to before the time of the Inca Empire. To this day, potatoes are transformed into a long-lasting, versatile food called chuños. This is done using a method that is the forefather of our modern freeze-drying.

Most people don't realize that some of the food they eat is preserved using centuries-old processes. These methods of keeping food didn't originate in a sterile laboratory.

The ideas were born years ago in rocky fields on high mountainsides in freezing temperatures. The ancients worried they would not have enough to eat if their crops failed or if hunting was scarce. These people

were the original food preservation experts or survivalists with their descendants still practicing many of their old ways.

Why the Incas Preserved Foods

Famine or food shortages were a major concern in the life of the Incas. One bad crop year could mean starvation. This, along with the reasons below, encouraged them to find ways to store food and prolong its usefulness.

- Natural disasters such as drought, hailstorms, tornadoes, fire and floods could destroy fields in minutes. Crops were also lost to animals, insects and some plant diseases.
- War diminished food stockpiles and it was common for enemies to set fire to fields.
- Preserved foodstuffs were a commodity that could be easily stored, transported and traded.
- Many times stored food was more valuable than gold or gems.

Archaeologists have unearthed evidence of even prehistoric man preserving the food they gathered or hunted. There have been examples of food that is thousands of years old found in various places across the globe.

Methods Used by the Inca Civilization

Incas in the highest reaches of Peru were using the freeze-wet-dry-repeat cycle for creating chuños as early as 3000 BC. Along with potatoes, other tubers, root vegetables and starchy foods received the same treatment. Each of these foods could be easily reconstituted with water to create nourishing meals. When properly stored away from moisture, the chuños or other similarly preserved foods could last for decades.

The Inca Indians were ahead of their time when it came to both farming and food preservation. Along with the freeze-drying technique for chuños, they understood the concept of freezing foods. The use of the sun and air for drying meats, fish and other edibles was also practiced. Salt was abundant near the coastlines and was used for curing as well as seasoning.

Runners from the various cultures served as both messengers and early day deliverymen. Methods of improved food production and preservation could be shared between the far-flung tribes. Increased productivity and improved ability to survive times of famine were due in part to the sharing of knowledge.

How To Make Chuños

The word chuño is an Andean term that means “wrinkle.” El chuño, as it is called, is the result of preserving the potato through dehydration. We assume that the name is due to the look that the potatoes take on during the process, which I will explain step by step:

Selection of potatoes

It is important that they are as similar as possible in size and shape. I have selected potatoes whose total weight is 2lbs.



Freeze first

In the past, the Quechua and Aymara tribes made chuño by placing the potatoes outside to freeze during the snowfall. Currently we have refrigerators, so

freezing them is a lot easier for us today. The potatoes have to be frozen in a freezer for 24 hours.



Place in the sun

At this time, you need to place them in the sun when it's at its most intense. Ten to seventeen hours is recommended; then express. You will notice that the potatoes adopt a wrinkled appearance (remember that is precisely what the term *chuño* means) and a soft texture.

At this point in the process, you must squeeze to extract as much water as possible from the potatoes. In addition to wrinkling, they are significantly reduced in size.

THE LOST WAYS II



THE LOST WAYS II

Refreeze

Once you have dried them in the sun, you should put them back in the refrigerator for the same amount of time as the first time.



Repeat in the sun

This time you will do it at the same time and during the same time period, but unlike the previous time, you will notice how the shell of the potatoes begins to become easy to detach. As seen in the picture, the potatoes continue to reduce their size, and where the shell has already detached, it begins to darken.

THE LOST WAYS II





Let harden

When you have frozen and sunbathed the potatoes twice, you must peel them completely and squeeze them to the maximum. You will notice that as they finish drying, they become very hard and dark. At this time, the potatoes will have already lost two-thirds of their size; this is because they have already lost all the water that they contained.

THE LOST WAYS II



As you can see in the picture, even though the potatoes selected went from weighing 2lbs to now weighing only a third of that, since all were selected uniformly, they still retain similar sizes between them.



This method is used to preserve food in a prolonged way, so potatoes that go through this process until

THE LOST WAYS II

becoming chuño can be stored almost anywhere as long as it is a dry place that is away from humidity.

The estimated time of preservation is indefinite. Some say that these potatoes can last several years, but it is recommended not to exceed 18 months.

HOW THE PIONEERS DUG THEIR WELLS TO PROCURE FRESH WATER

- By John Paicu-

*“Wisdom prepares for the worst,
but folly leaves the worst for the
day when it comes.”*

- Richard Cecil

Between the 1700s and the late 1800s, hand-dug wells became extremely popular in North America along the east coast. John Robert Shaw, a famous well digger of the period, dug over 177 wells in four years, totaling 795 meters in depth. He claimed to be very good at locating and digging both fresh water and salt water wells using a method called “water witching,” or “dowsing.”

The practice involved walking along a property holding a forked stick, a pendulum, and two L-shaped rods to locate the water underground. The witching rod rotates in the hands of the person walking the

THE LOST WAYS II

property and points toward the ground when a water source is spotted.

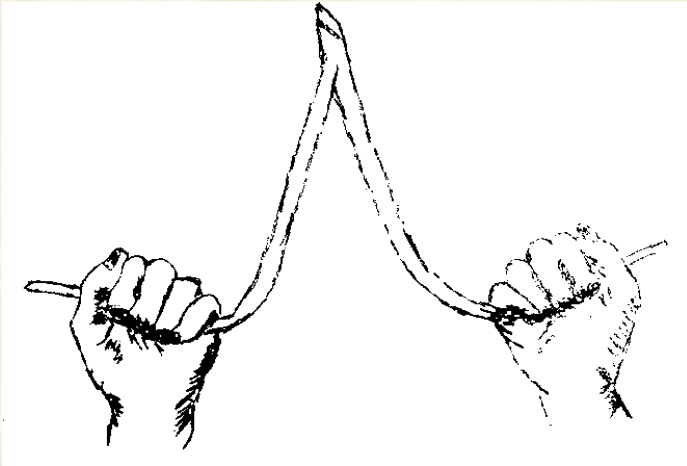

Early settlers dug wells in gravel deposits and sand. They used explosives to achieve the required depth, and then they would carve the hole with rocks to separate the water source from the surrounding ground area. A well's diameter had to fit the digger, who had to then go down the excavation to drill the holes with a hammer and drill.

Black powder was used to pack the holes, and after lighting the fuse (safety fuses were developed later on, in 1831), the digger had to climb up very quickly, before the well blasted into the rock. Since lighting a fuse was dangerous, hot coals were thrown into the well to activate the black powder and excite the well.

THE LOST WAYS II

The black powder was made of an absorbent and nitroglycerin. You'll find the exact procedure together with pictures in *The Lost Ways I*.

Before being used to make dynamite, it was exclusively meant to blast rock. Wells dug in gravel or sand were lined with brick or cut stone. Cribbing and wood were also common materials used for the lining; however, because wood accumulates humidity and eventually rots, it had to be substituted.



THE LOST WAYS II

After achieving the desired depth for the well, brick and stone were used from the bottom up to frame the well. At the top, a wooden, brick, or stone curbing was built around the well (four to five feet in height) to prevent debris from going into the well and affecting the quality of the water. For a smoother aboveground curbing finish, mortar was often used as a bucket and windlass base.

In the Western frontier cities, the wells were dug close to stores and in town squares for everyone to access them. The first one was reportedly built in 1839, in Austin, Texas, with a depth of 20 feet. Later on, deeper wells over 250 feet were dug in Western Texan regions. The digging part was done with shovels and picks.

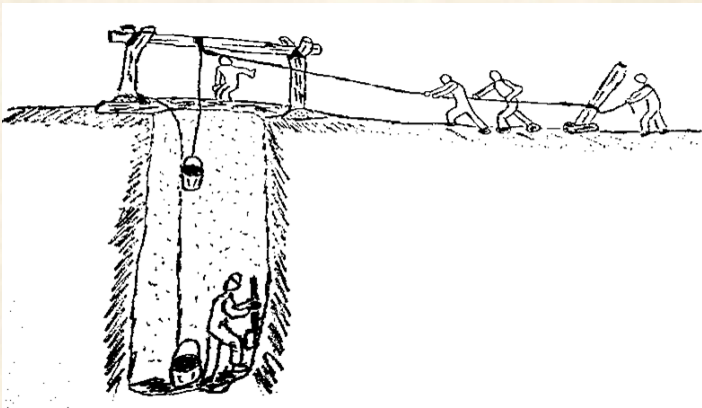

Well drilling technology used by the pioneers

The Chinese were the first to use the percussion method to construct wells. They've been using it for 4,000 years. The wells were dug at staggering depths of 3,000 feet.

The percussion system involved frameworks made of bamboo to permit the increase and drop of a heavy crushing or chiseling tool. Today's cable tool rig used for drilling descended from the bamboo framework that the Chinese used to dig their wells.

In America, the first spring-pole well was drilled in 1808, in West Virginia. The depth of the well was nearly 58 feet, and the water was salty.

Soon after the discovery was made, the area became a well-known salt manufacturing center. In North America, the pioneers of the drilling method were the Ruffner brothers, who later helped drill the first oil well in the U.S., in 1859.

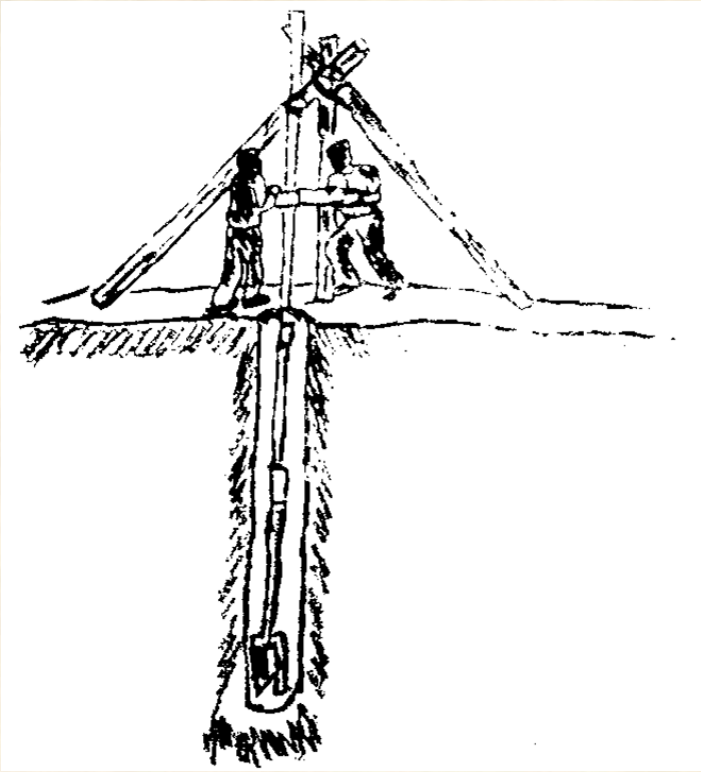

Spring-pole well

Around that same period, many wells were built using the spring-pole. In spite of a simple design, the technique required time and strong legs to be completed. It involved using a long pole, some sort of heavy device to anchor the butt end (e.g., a heavy rock), a stirrup, a fulcrum, oak rods, a manila rope, and downhole tools. Hemlock was the preferred type of wood for the pole because it was durable.

THE LOST WAYS II

- The butt of the pole had to be anchored to the ground using boulders to stabilize the butt. To secure the butt, wooden structures with clamps and a lintel were used.
- The stirrup was hung by the spring-pole, close to the intended position of the well's borehole, about 3 ½ - 4 feet from the pole's end.
- The tip of the spring-pole was brought down when the driller pushed it with his leg. Oftentimes two stirrups were added to allow two men to work on the same well.
- The drill spring (made of a series of vertical tools) was fastened from the pole's end (about 3 feet). The components were oak rods or manila rope, metal connectors, a sinker bar, a rope socket, auger stems, jars, and a bit. The auger stem was a solid iron bar about 3 inches in diameter.
- Above the borehole, a high tripod had to be erected, and pulleys were suspended from the tripod's apex. This maneuver allowed the builders to pull the drill string when changing the tools or when bailing out the hole.
- A bailer tool was used to retrieve accumulated cavings and cuttings, thus cleaning the well's hole before resuming the percussion drilling process. Later on, the tripod used by the pioneers became the derrick we know today.

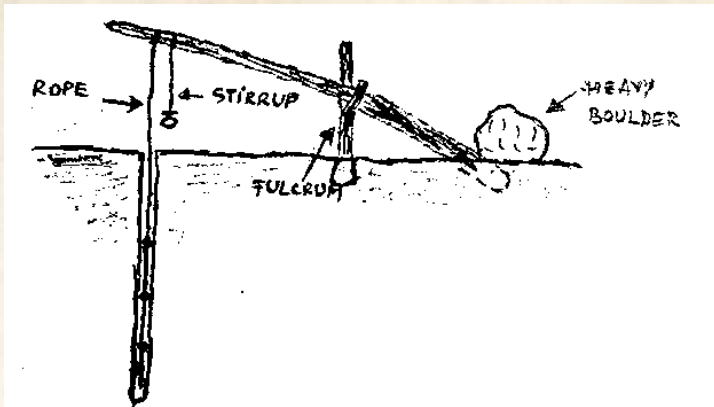

Treadles & teeter-totters

In the late 1800s, different arrangements were tried out in an attempt to ditch the leg power used on a spring pole. It was a reliable technique, but it demanded too much strength and endurance. Different “devices” were invented to replace sore legs. However, some seemed a bit too exaggerated. At some point, welders began using horse-powered machines. Horses were placed on a treadmill (usually made of wood), and they were compelled to trot continuously to help operate the walking beam rig.

Steam-powered drill rigs

Steam-powered drill rigs came around the same period. When steam power became available, it started competing with the many walking beam devices. In 1841 the spring pool driller was finally

patented. It allowed for many abandoned wells to be reopened. A more sophisticated tool that didn't require a spring pole was made available. It was known as a portable "horse-driven spudder rig." A horse was used to turn the heavy fly wheel, pendulum bar, cam, and elbow lever. All of these combined were meant to drag and drop drilling tools.

The walking beam

The history of a walking beam being used to build a well is hazy. Apparently, it became available around the same period as the spring pole, in 1810. Securely sustained by a samson post, the walking beam was developed into a standard device used for cable tool rigging later on, in 1870. It played a fundamental role in the formation of the conventional derrick. Early samson posts were about 10 feet in height. Due to a middle pivot, the center of the beam moved and balanced freely on the post, triggering up and down motions.

How to Dig and Build Your Own Well Like the Pioneers

Early wells dug by the pioneers of the 18th century were basic shallow pits near springs, lakes, and streams. To purify the water, they would use sand, and the well's perimeter was delimited with rocks. Before

entering the well, the water had to filter through the sand.

But because the pits were shallow, the water was predisposed to contamination. Soon enough, they started digging deeper wells in search of a more permanent water stream.

Before getting started, you should know that any well has to have a well casing. It is fundamental because it prevents the sides from falling apart (and it guarantees that the water is fresh and bacteria-free). To make your own well, you can even dig the hole yourself with a shovel, use an auger, or use a device such as an excavator to speed up the process.

Find a water stream near your home. Apart from the obvious ravines, assess the vegetation in the area. If you see cottonwood trees, reeds, willows, or cattails, then there's a permanent water stream passing through the ground somewhere. Start digging test pits or holes.

Wait one day to see if the dug area accumulates water. Start digging, and make the pits between 12" and 24" deep. In the beginning, the goal is to capture at least a few drops, just to provide some guarantee that you've chosen the right spot. Mark the location where the most water accumulates.

THE LOST WAYS II

Keep digging at a depth between 6 feet and 8 feet. As you dig deeper and deeper into the ground, make sure to shore and mark the sides of the well. Use pieces of lumber as temporary support with an average diameter of 2" by 6". Their purpose is to hold back the walls of the well.

After you've reached your desired depth, keep going and over-dig in the middle of the hole. Start placing flat bricks or stones to craft the base. As soon as the base is finished, remove the bottom braces (the temporary support made of lumber). Don't worry if you notice some soil sluffing in.

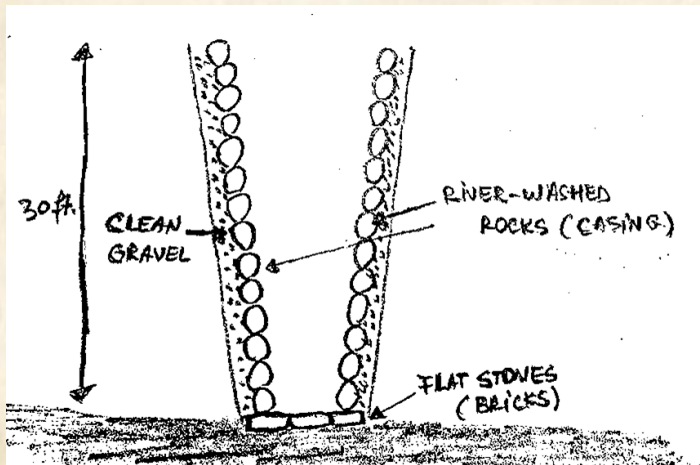

Use large rocks (river washed) with an average diameter between 6" and 7" to make a circle, starting from the bottom up. This will be the first layer of your

THE LOST WAYS II

well's base—the casing. If you can, it might be a good idea to use coarse gravel to backfill the rocks to create even more support for your well's outer wall and to permit the drained water stream to fill your pit.

Keep building the ring of rocks until you get to the top, tapering your well's rock wall casing as you go. At the bottom, make it smaller and then slightly larger as you climb up. This technique is two dimensional, and it is meant to provide stability around the wall casing of the well. Basically, you're "encouraging" the water to come from the bottom. Keep digging the pit, and remember to use flat, river-washed stones at the bottom. Coarse the gravel to filter the incoming water.



The construction of the walls for your well's casing is done in the same way as for the underground sides. Make sure to block any sort of surface water from entering the well. At the end, before cleaning the well,

THE LOST WAYS II

take a small water sample. Start drawing as much water as you can—the depletion and refilling flushes out lighter materials and sediments so that you have a useable water source. Take another sample.

Toss two cups of chlorine bleach (unscented) into the well, and don't do anything else for 24 hours. Then pump all the water out of the well four more times. If you can still smell the chlorine, keep pumping the water out until the water becomes odorless. Take another sample, and take all three samples for testing to be sure that the water is safe to drink.

DEER HUNTING BASICS AND STEPS TO HIDE TANNING

- By Hunter Riley –

*“We will see the day when we live
on what we produce. “*

- Marion G. Romney

Deer hunting is as old as civilization and provided our ancestors with a source of lean protein as well as material for clothing and shelter. The last 100 years has seen a shift away from hunting deer out of necessity into one of sport and keeping our hunting skills sharp, a tribute to those ancient humans.

It's a stretch even to attempt to cover how to hunt deer in such a small amount of space, but we are going to lay out the basics of deer hunting for those looking to begin a lifelong pursuit.

As we will discuss, the practice of utilizing everything a deer has to offer has seen a renaissance in the hunting world, a trend we hope continues. Everyone knows what to do with the meat, but an often-underutilized part of the deer is the hide. In this

chapter, we will also take a look at the steps to correctly tan a whole deer hide.

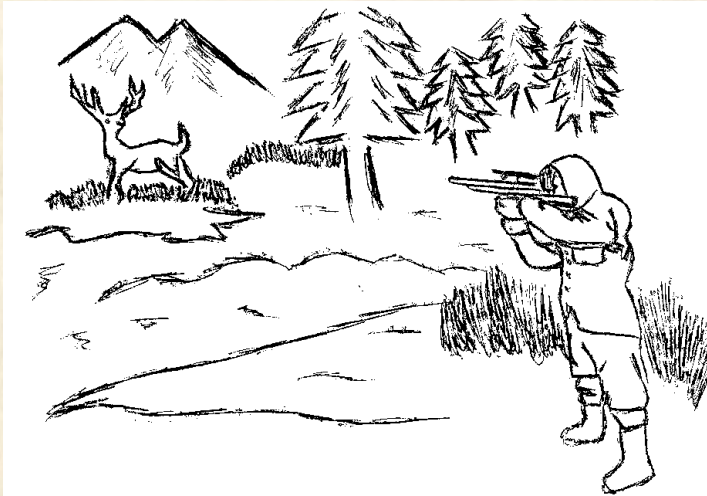

Deer Hunting Basics

We're going to go into this with the assumption that you understand the basic gear involved with deer hunting. You know, the gun or bow and camo.

What we want to outline in this first section are the basics of locating deer, understanding their behavior, and how you go about finding and setting up for a harvest.

What Deer Need

Having a basic understanding of what deer need to survive allows you to make your initial scouting much more efficient.

So, what do deer need to survive?

Water is of course, essential for all living creatures on Earth, deer included. Deer normally do not have large home ranges and generally will stay around a five mile or less radius. If you can find a water source such as a pond or creek, there is going to be a deer population in the area.

One of the first steps to scouting an area and determining where deer traffic is found is to determine food sources in the area. If there are crops in the area, you can bet that there will be deer feeding in those areas consistently early in the season and up to rut.

Deer also feed heavily on browse, such as woody plants, as well as mast (nuts and fruits). All of these foods are going to attract deer and during the early and late season, should be your focus point and branching out from there to find deer.

THE LOST WAYS II



Deer also need a form of shelter. This often in the form of heavier brush or thickets where they can escape from predators. These areas are also places deer like to bed down. You will often find deer holding, especially in the colder winter months, on the southeast side of embankments or land rises which protect them from brutal winds.

If you can nail down these three requirements from scouting and maps, you can be confident that you will be in an area that is patrolled by deer.

When Deer Move

Understanding when deer are the most active allow you to be in the woods during these times. For just about any time during the year, especially during the

THE LOST WAYS II

season, deer are usually going to be more active at night making the best times to hunt them early in the morning, when they are moving back to bed, and late in the afternoon when they are moving to begin eating.

This is not always the case as there have been thousands of deer taken in the middle of the day. Regarding activity though, early daylight hours and the last two hours of shooting light have the highest deer activities.

Things can change during the peak of the deer mating season, the rut, where deer are moving just about at all hours of the day.

The most important aspect is not only understanding when deer are moving but their routes. Deer are creature of habit and will often hold to the same travel lanes if not disturbed.

Scouting before the season and looking for tracks and scat in areas where there is a noticeable path through the woods or vegetation will give you a decent idea of these travel lanes and can be extrapolated to feeding and bedding areas.



Deer Behavior in Different Seasons

Though this is a generalization, for this chapter we can split the normal deer season into three distinct time periods based on how deer are behaving.

Early Season:

During the early season deer are focused on feeding, and they are feeding hard. With scouting and observing deer movements, you can pin down times and locations of deer movement. Though it's much easier said than done, the early season is the easiest

period for predicting when and where the deer are going to be at.

Rut:

We could write a book, and there are several out there, on deer behavior during the rut. Rut often occurs around the first real cold snap and usually ranges around mid-November in most areas. During this time, bucks are searching hard for does and breeding takes the place of feeding. It's much more difficult to predict deer movements during this time. If you have located rubs and know areas where deer are localizing, you can use estrous scents and even rattling to increase your chances of success. There will also be periods during the rut where deer activity seems to fall off dramatically. This is because a lot of bucks are bedded down with does and can last for several days. Activity usually picks up back to rut levels shortly after.

Late Season:

After the rut has concluded, usually after two to three weeks, the focus switches back to feeding. Deer are in their worst state of the year at this point and are in high need of food after spending the last month breeding. If there are winter crops in the area, these will be magnets for deer. Browse is most often the top

food source in non-agricultural hunting grounds as well as any leftover mast from earlier in the fall.

How to Set Up

There are several strategies for getting the drop on deer. If you have done your homework and have an idea of the general area deer are in, and their travel lanes, the most common method is an ambush. Setting up a tree stand or blind along these areas with clear shooting lanes and sitting and waiting for the deer to show up.

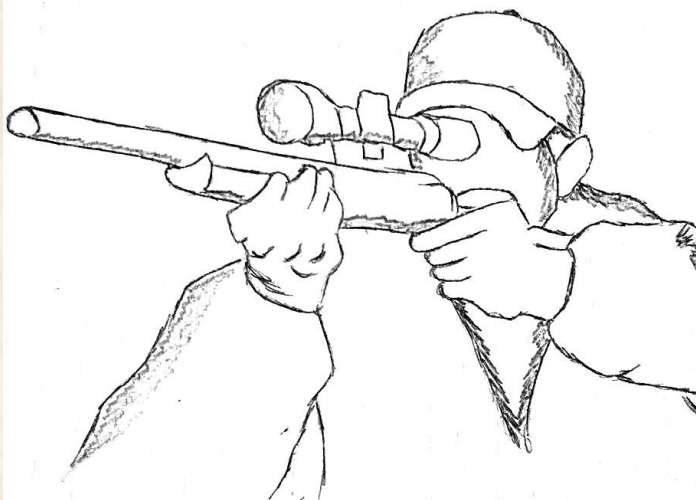

How close you are to travel lanes or feeding areas is going to depend on your choice of weapon as well. With a rifle or muzzleloader, there is no reason to be set up in dense growth right over or on a trail where

THE LOST WAYS II

your chances for spooking deer is much greater. All situations are different, and part of becoming an efficient deer hunter is putting yourself in those positions and having success and failures and learning how to adapt to what is around you and how the deer are behaving.

Scoping or glassing deer from a distance and then positioning yourself for a shot is another popular method and demands more physical fitness and another level of strategy. This method is great when hunting more open areas that contain changes in elevation where you can view large areas of land. In dense woods, this tactic is much more difficult.

Regardless of the tactics that you choose to go with, there is a level of woodsmanship that goes along with success. You need to keep your sound and scent footprint down to minimum. Being quiet in the woods just comes with practice, but you can always be cautious with your scent.

Using a scent masker is a good start, but more than anything you need to have yourself positioned downwind of where you expect deer to be. You can have all the equipment, done all the scouting, and have a fantastic setup, but if you have not accounted for the wind direction and yours and the deer's location, it will all be in vain.

After the Harvest/The Hide

At the advent of hunting, taking a deer was not just a sport but a means of survival. Too often hunters simply take the animals for the antler rack and neglect such valuable parts of the deer. We have seen a trend back towards the full utilization of the deer, and we believe it is for the best.

Even with this trend of taking advantage of all of the resources a harvested deer can provide, the hide is still shamefully neglected. Most often the deer hide is used for decorations purposes, but the hide and buckskin can also be used to make wonderfully soft and beautiful garments and pouches if you have or know someone with the requisite skill set. Tanning your hide is also going to save you a good deal of money compared to farming out the process to others.

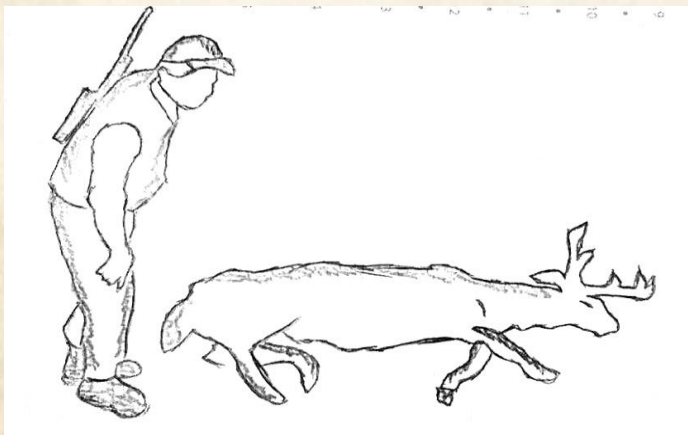

Tanning Guide: Step by Step

Removing the Hide:

We are going to focus more on the tanning process than the removal, but generally, we like to work with a hide that has been removed from above the tarsal glands on the back legs to below the jaw. This gives a full hide that can be used for a variety of clothing or decoration purposes.

All cuts should be made on the inside of the body as this will make a better-looking hide in our opinion. You will also need to debone the tail if you want that part of the hide included.

Removing the Flesh:

Once the hide is removed, you will notice that the underside of the hide still has a layer of cartilage and other tissue. Removing all of this is critical to having a well-preserved hide and makes the tanning process much more effective. We don't like using a sharp knife; it is too easy to cut through or damage the hide.

A duller knife that still has a slight edge is the best tool to use. This process is extensive and time-consuming, but it has to be done to have an evenly tanned hide. You will notice a white layer of skin, and this is right

below the hairline. Be sure to not cut through this layer.

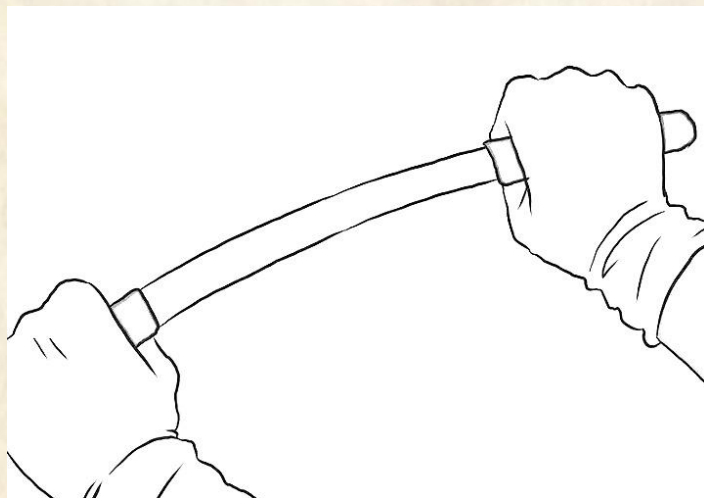

Hair or No Hair:

From here you have two options for the hide. You can keep the hair on or remove the hair to make buckskin. If you want to move forward with the hair intact jump ahead to step 5. To remove the hair from the hide and make a buckskin, mix 1 gallon of hardwood ashes, 2 pounds of household lime (slaked), and 5 gallons of warm water. Stir the mixture until everything is dissolved.

Completely immerse the deerskin in the mixture. Stir the mixture several times a day until the hair comes off easily. This will take at least 2 to 3 days and maybe

a fourth. Be sure to check every day, keeping the skin in this solution for too long will cause it to deteriorate.

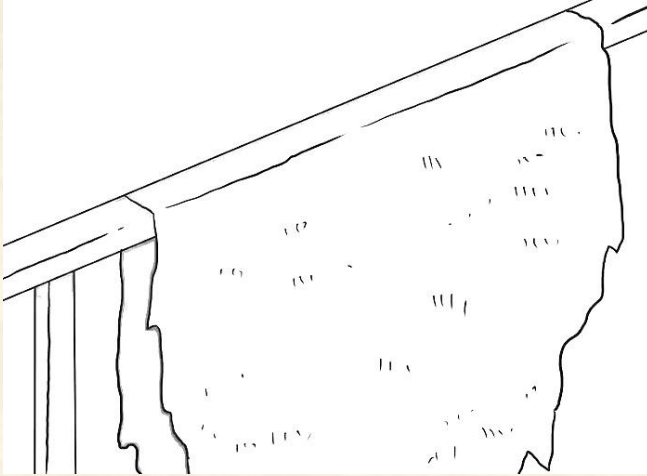

Removing the Hair:

Place the hide on a raised surface with the hair side up. Use the back of a knife to scrape off the hair and then rinse the skin several times with clean water.

You then need to soak the hide for 24 hours in a mixture of 5:1 ratio of water to vinegar. Stir this mixture with the hide in it every few hours.

Once the skin has soaked for 24 hours, soak the hide in the clean water overnight. This step neutralizes and removes the lime and ash mixture and keeps the hide from deteriorating.

THE LOST WAYS II

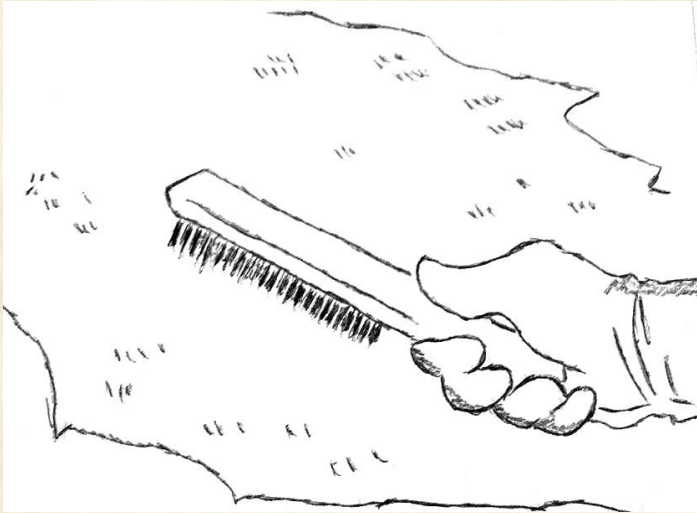

Salting:

Once you have the flesh removed and/or removed the hair it's time to salt the hide hard. You can't over salt the hide, so be sure to be generous with it. We like non-iodized salt because it will not cause the hide to stain. What the salt is doing it drying out the moisture from the hide.

Several pounds of salt should be used. Work it into the hide and let the hide sit overnight. From here you can continue with the tanning process or freeze the hide for later work. Salting also helps loosen up any leftover pieces of tissue so be sure to go through one more round of scraping before moving on.

Cleaning the Hide:

Before we get into the actual process of tanning, you need to wash as much of the salt off the hide as possible. We like to soak the hide in several gallons of clean water for several hours and then going over the skin side of the hide with the backside of a knife or a similar surface. Having absorbent towels to blot dry is also very effective.

Tanning:

There are some options you have for tanning the hide. There are commercial tanning solutions that are probably the most convenient. Another option is a salt/aluminum alum solution. The commercial kits often come with directions and usually take 4-5 days of soaking the hide or just rubbing in the solution and letting it sit for several days.

We soak our hides in large trashcans or buckets that will be able to hold at least 8 gallons of water easily. The most common homemade tanning solution is made from 2.5lbs of salt in 4gallons of water with 1lb of ammonia alum that has been added to 1 gallon of water and is slowly added to the salt solution. The hide should be stirred several times every day. Some tanners will tell you to refrigerate the soaking hide, but as long as the weather outside is staying under

45°F, it should be fine outdoors as long as it is covered.

Draining the Hide:

This step is especially important if you have to soak the hide for several days rather than let the hide sit with a tanning solution rubbed into it. When using a soaking method, take out the hide and rinse it gently with water and allow it to drain for an hour. You do not want it to dry out completely as it is much more difficult to soften the hide in this state. Once you have a moist hide that is not dripping, we like to add some oil or fat liquor into the hide.

Softening the Hide:

At the end of the tanning process, however, you went about tanning and drying, you're going to have a stiff hide. Our favorite way to work the stiffness out is to use a saw horse, but any line or piece of flat surface you can pull the hide over will work. As you stretch the hide and work it over the flat surface, you will begin to tell by feel the leather begin to loosen up and have a more subtle feel.

As the hide dries, moisten the skin lightly with a spray bottle of damp cloth and pull the hide back and forth over the sawhorse, dampening the hide as

THE LOST WAYS II

needed, until you have the hide as soft as you want it. During this process, you can also continue to add some oil or fat liquor as needed.

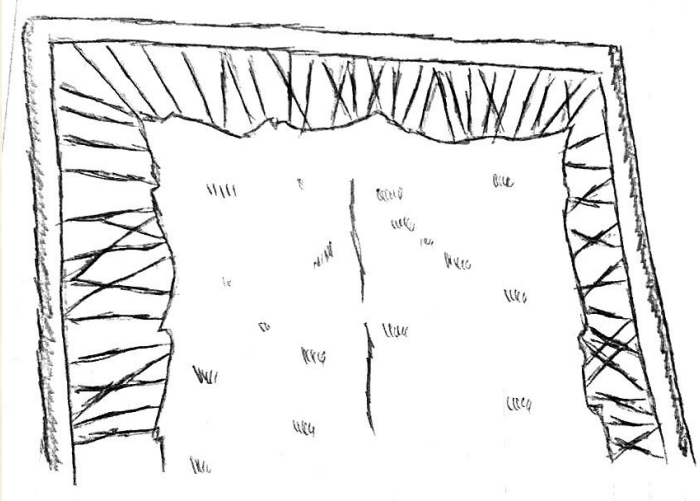

Conclusion

Hunting deer is a long process. It begins with scouting the land and studying deer movements, moves to getting boots in the field trying to harvest a deer, and hopefully ends with you utilizing as much of the deer as possible.

There is a plethora of information on deer hunting that is available. This is by no means an in-depth discussion on the intricacies of deer hunting, but we hope that it outlines some of the basic ideas behind the sport and

THE LOST WAYS II

provides a proven and detailed guide on how to utilize one of the most underused parts of the deer. You might find it time-consuming or you might find that it becomes part of the ritual of harvesting deer. Whatever it becomes, we hope you at least try it once.

HOW TO MAKE A NATIVE AMERICAN BOW AND A BONE ARROW (WITH PICTURES)

- By Arminius -

“Expect the best. Prepare for the worst. Capitalize on what comes.”

- Zig Ziglar

When the Native Americans crossed the land bridge from Asia some 11000 years ago they were not hunting with bows. They, like most paleolithic cultures were still relying heavily on the spear. Though it was an effective enough weapon to settle them in the great abundance of North America it simply didn't have the power, accuracy or efficiency of a bow.

The truth is, no weapon has stood the test of time the way the bow and arrow has. This is in part because it still is an efficient killer. There are large numbers of traditional archers that shoot the bow in its purest form. They call it stick and string though the design of

THE LOST WAYS II

the recurve and the long bow warrant a little more credit than that.

The first bow and arrow didn't hit the Iowa plains till about 500 A.D. This information has come from archeologists studying the area.

American Indians did not always have the bow and arrow. It was not until about A.D. 500 that the bow and arrow was adopted in Iowa some 11,500 years after the first people came to the region.⁶²

One of the biggest benefits that came from switching over to bows from spears was the amount of materials needed to create the weapons. The bow was used over and over and the arrows required much less time and material. This made a significant difference in hunting and in Native American wars.

The bow affected Native American culture so thoroughly that bows and arrows began to show up in tattoos, art and held symbolic meaning in tribes across the nation. There is no denying that this weapon, though it arrived late by the world's timetable, became

⁶²American Indian Archery Technology,
<https://archaeology.uiowa.edu/american-indian-archery-technology-0>

THE LOST WAYS II

synonymous with those who shot it on the plains and in the forests of North America.

- **One Arrow** – When the solo arrow is depicted it often signifies defense from harm or enemies.
- **Broken Arrow** – The broken arrow shows the end to conflict or the burying of a hatchet. This was a peace symbol after conflict.
- **Two Arrows Pointing Away From Each Other** – Opposing arrows meant just what you think. This signified war among tribes.
- **Two Arrows Crossed** – This was a symbol of friendship in both personal and tribal means.
- **A Bundle of Arrows** – A collection of bundled arrows is meant to signify strength. One arrow can easily be snapped while a bundle can be nearly impossible to break.
- **Bow and Arrow** – The depiction of the bow and arrow represents the protection of family and loved ones.

The methods and materials in creation of these bows is most spectacular. You may think young saplings when you consider the base of a bow and arrow. The truth is there was incredible diversity in the materials used to make the actual bow itself.

THE LOST WAYS II

Ash, hickory, locust, Osage orange, cedar, juniper, oak, walnut, birch, choke cherry, serviceberry, and mulberry woods were used. Elk antler, mountain sheep horn, bison horn, and ribs, and caribou antler also were used where available.⁶³

The same diversity of materials went into the creation of things like fletches, arrow shafts and arrow heads. Arrowheads were made in many ways and crafted from various materials. The arrowhead is what causes the bleeding that kills prey. It's of the utmost importance that these be razor sharp. There were even leather arrowheads!



64

⁶³ American Indian Archery Technology,

<https://archaeology.uiowa.edu/american-indian-archery-technology-0>

⁶⁴ Walters Art Museum by Henry Walters, Public Domain

THE LOST WAYS II

The move from throwing spear to bow and arrow made the Native Americans more efficient killers and this was great when it came to hunting things like bison and elk. It was a terrifying improvement when it came to warring tribes. This technology also increased their ability to slaughter one another. Not simply a benign weapon for procuring food the bow and arrow was a weapon of war.

When it was combined with the speed and power increase on horseback the Native Americans had serious domination over the land and those without horses. They could chase down bison or surround enemy tribes. Like the dominating clans of Genghis Khan in the Steppe they used the combination of technologies for domination. Only the “firestick” had the ability to match these horseback archers.

The bow is and was a nearly silent killer that carries well. It’s still an effective weapon today when hunting game. To the woodsman or survivalist, knowing how to make a bow from the surrounding woods will offer an incredible edge. It will give you the ability to strike from a distance with lethal force. It also offers self-defense from animals more well equipped to take you out.

You will learn how to craft a bow just like that which the Native Americans used to hunt for food and

defend their tribes. You will also learn the technique of making razor sharp bone arrowheads.

Tools:

- Wood
- Carpenter's pencil
- Wax crayon
- A piece of shattered glass (optional, but will give you a smoother result in the end)
- A finer and a harder hone
- Some sort of universal glue
- Tape measure
- Hand saw
- Drawknife
- Ax
- Carpenter's saw
- Work gloves
- Sandpaper
- Round file
- Flat file
- Triangle file
- Smaller and bigger chisels
- Knife
- PVC pipe with one of the ends sealed off



Getting the Wood

For a Native American bow, you will need to find a branch that's two to three inches in diameter and around four to six feet long. It has to be straight and cannot have any other branches on it. I chose the branch in the middle.

Choose a tree that's durable and hard but also flexible as we will be bending it quite a lot. I would recommend going with one of the following trees for success: yew, maple, ash, acacia, cornel, hazelnut, hornbeam, or mulberry.



Drying the Wood

The best option is to leave the wood inside to dry for at least half a year, but the ideal is one to two years.

If you don't have time to dry it, put it underwater for a month. The best option would be if you have a river close by where you can keep the wood. After it's been soaking for a month, take it out and place the wood inside a dark, dry place. In about another month, you will get a piece of wood that is bow worthy.

THE LOST WAYS II



The wood I was working with was around 5.10 inches. The smaller side of it was two inches in diameter, and the larger side was four inches.



Preparing the Wood

I cut the wood into two pieces using two axes and tried to get it as straight as possible.



If you do it right and both pieces come out perfectly straight without any burls on them, you can have two chances at making a bow. If you do end up with a burl, just drill a hole into it. Use some wood glue and a wood dowel of a different type of tree; place it inside the hole and leave it for 24 hours to rest. After that, you will have a wood piece that can be worked into a bow.



THE LOST WAYS II

After cutting it in half, I got rid of all the bark from the wood with an axe, but you can also use a drawknife.



Giving the Bow Its Shape

I took the wood and marked out 3.14 inches from the middle on both sides. This will be the handle.



THE LOST WAYS II

I drew out the form of the bow on the other side of it and started chipping away the back side (the side that faces you when you draw the bow).



I drew out a piece of plastic rope in a way that the rope would be in the exact middle of the handle and fiddled around with the positions on both ends until I got it.



THE LOST WAYS II

As you can see from the pictures, the line might not fall into the middle of the wood depending on the curvature of it. I drew some lines one inch away from the rope. This will gave me the area I can work on.



Then I drew another line with the wax crayon. At the handle, I marked a point at the one-inch mark on both sides of the rope, and on the end of the wood, I drew a half-inch point based on the rope and connected the lines.



THE LOST WAYS II

With the help of an ax, I cut away the extra that I didn't need until I got the form I wanted.



Smoothing It Out

From this point on, I only worked with the drawknife. I started cutting away at the front of the bow, taking away the smallest pieces I could, until I completely removed the upper layer.



Now, with the help of a drawknife (you can also use a knife), I started giving it the form I wanted.



THE LOST WAYS II



After working the wood down to the form I wanted, I had marks on it like these. I worked it down with a sander.



THE LOST WAYS II

After that, I cut out the place where the string would go later on.



I worked it down to a round form with the round file.



THE LOST WAYS II



After that, I started working on the bigger cuts I got from working it with the drawknife.



THE LOST WAYS II

With the help of the broken glass, I was able to smooth it out even finer. I just went over the wood with a scratching movement until I felt it was good enough.



And to finish it off, I went over it with the sand paper, first using the rougher one and then the smoother one at the end to finish it off.





Bow Bending

First of all, I needed to make a bow bending piece of wood to put it onto. I used a three-foot-long wooden plank for it. I made a cut on the piece of wood at around one inch for every cut, making the cuts so the bowstring could get caught on them.



THE LOST WAYS II

I grabbed a piece of the plastic rope, put it onto the bow loosely, and placed it onto the bender, slowly going down on it and watching the bow to see how it was bending. You can see that on the left side, the bow is straighter, so I had to work that down.



I grabbed my knife, and as gently as possible, taking away as the least amount I could, I started scratching it down. You can use a glass shard in the same way for this job.



THE LOST WAYS II

You will have to do this until you get the perfect form.
It should look like a parabola.



Here's another look at it.

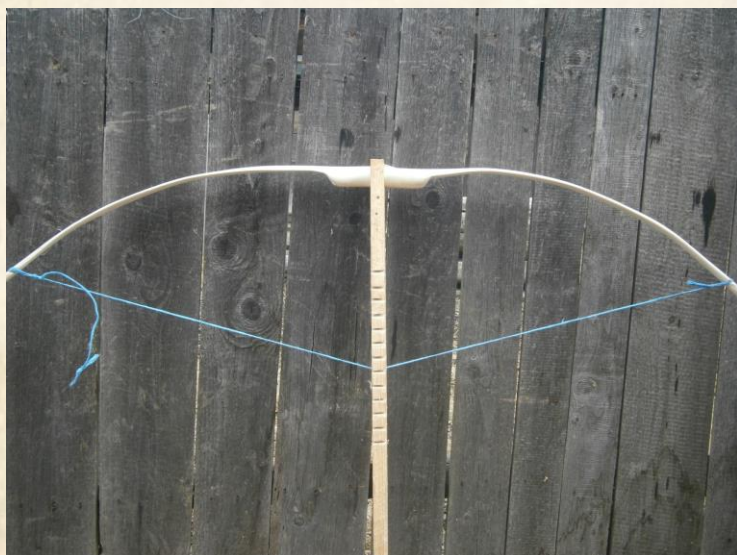

THE LOST WAYS II

You know you have the perfect size and form when you place your hand onto the handle and give a thumbs up to yourself for being awesome and building your own bow. If the string just barely touches the tip of your thumb, you have what you are looking for.



To preserve and protect it, I coated it with linseed oil three times with a day in between them. Make sure to only give it a light coating.



Covering the Handle with Leather for a Better Grip

From an old leather jacket, I cut out around 0.40–0.50-inch-wide strips and attached them with the glue until I got a 4.11–6.6-foot-long strip. I also got a smaller piece of a leather strip that will be used later to finish the job off.

After they dried, I started putting on the leather by holding one end and placing it onto the handle's halfway point.



I held it in place with my left hand and started going around the handle and covering it, making sure to go real tight.

THE LOST WAYS II

I did this until I got close to the other side of the handle and until there was one inch left to cover.



I grabbed the extra leather strip I had, made a loop with it, and placed it so that it was overhanging the already covered handle, making sure that the loop end hanged over the place I wanted the end of the leather to be. It should hang out 0.75 inches.



THE LOST WAYS II

After I reached the end, I pushed the end of the leather strip through the loop, carefully holding it so it wouldn't unwrap.



I held onto the loop and started pulling it through until I got the end of the cover completely under itself and the loop came out.



It ended up looking pretty awesome. I just finished it off by cutting off the little part that was sticking out.



Making a String out of Intestine

I went out to my local shop and bought myself some pig intestine. It usually comes salted, so I made sure to get rid of the salt by rinsing the inside and the outside thoroughly with water. Make sure to cut off any fat if you see any on it; fat doesn't shrink much when dried, and it might make the gut string look uneven. Just use a simple knife to cut away any bigger fat chunks you might see.

THE LOST WAYS II

I chose four pieces that were the size of the bow and laid them out. The best is if the gut is 9–18 inches longer than the bow.



If the pieces are not long enough, you can always splice them into one. Lay out the ends of the guts onto something and flatten them out. Cut two tiny holes into them.



THE LOST WAYS II

Put the end of the first gut into the second gut's hole, and put the second gut's end into the first gut's hole so they form a circle.



Start pulling them together until the two become one. Wrap the flattened ends onto themselves to finish it off.



THE LOST WAYS II

I grabbed two of the guts and tied them onto a nail that I hammered into a plank that was longer than the guts. I slowly started to twist the pieces separately the same way then crossed them over each other.

Once again, I twisted them separately and then over each other until I reached the ends of the guts.



After I reached the end, I tied a knot and put them under pressure, letting them dry for 24 hours. I did the same with the two left intestines and let both of them dry. I used intestine to hold everything together, so I placed some extra pieces on as well.

I just let these sit by themselves with some pressure on them and let them dry for 12 hours to be able to work with them but get them stiff enough to hold everything together.

THE LOST WAYS II



After they dried up nicely, I grabbed them and measured out three inches on them. I tied it at that point with a piece of gut and started twisting and crossing them over each other the same way.

I did this until I reached roughly over three inches and then put the open end of the gut over them, twisting the two ends onto the guts and continuing the process so it made a loop. I continued until I reached the end and then tied a knot onto it to finish it off.



THE LOST WAYS II

I grabbed some beeswax I had left over and heated it up to cover the gut string.



I made sure to do a light coating on it, just enough to barely cover it. This will help the gut stay dry and protects it.



After that, I put the looped hole onto the bow and tied the other end tightly onto the bow. The looped side will be where we move it to a resting position when not in use, and the other will stay fixed.

Making the Bone Arrow

I cut down a branch from my willow tree that looked to be the straightest out of all of the others. The best is if you can find a straight branch, but even if you can't, work on making it straight.



I removed the bark from it and started working on straightening it with sandpaper and a knife. Go to the places that seem bumpy, and work on them until it all becomes relatively straight. Sandpaper also helps

THE LOST WAYS II

smooth the wood out, so it's not a bad idea to go over the whole arrow a few times.



The ideal arrow is around 8–9 mm in diameter. Mine was a little off—one end was 9 mm, and the other was 12 mm. The length was 31½ inches.

THE LOST WAYS II



I took my PVC pipe and plugged it up with a wine plug.



I then filled the pipe up with linseed oil and put the arrow inside. Do not fill the pipe all the way up with the oil— trust me, you don't want to put the arrow in and see all your oil pour out the top. I'm talking from experience....

The best thing to do is to put a little in and test it with the arrow until the oil covers the arrow. Then leave it in.

THE LOST WAYS II



The length of the pipe should be the same as the arrow's length to cover it completely. The oil will go one mm deep into the wood and give it a nice, protective coating against water. I left it for 24 hours, but I'd recommend leaving it for at least 48 hours.



THE LOST WAYS II

On one of the ends, I cut in a 1.4-inch deep cut; this is where I will put the arrowhead later on.



On the other side, I made the place for the string to go when drawn. The hole I cut out was 6 mm wide and 12 mm deep. I put some leftover dried gut onto it for extra support, and it also adds to the look.



THE LOST WAYS II

I worked the hole I made for the arrowhead a little more with the file until I thought it would match the size of the bone I was going to use but not hold the head too tightly.



I also made the head rounder to help it look more continuous and to help it enter the target easier when shot.



THE LOST WAYS II

I did the same with the other end too. The little details make it look more special.



I stole a piece of beef leg bone from my dog and cut a good piece out of it with a saw. The rectangle was one inch by two inches.



THE LOST WAYS II

I simply cut it into an arrowhead shape with the saw. For now, it's enough to just make the triangle point; it doesn't have to be perfect.



With the help of my file, I worked it down into its final shape and made the end that will eventually be going into the arrow's body.



THE LOST WAYS II

Then I started working at the edges. First, I used a wetted file; then I went over to a rock that would be good enough to give even a knife a sharper edge.



I then finished it off with a smoother rock. I ended up with a really sharp head that was at least as sharp as a traditional knife.



THE LOST WAYS II

I placed it into the arrow's body and wrapped it tightly with some guts to hold it in place.



Putting the Feathers on and Trying It Out

First, I made some marks on the back of the arrow at three points at every 120 degrees so they were even. This is where the feathers would eventually go.

I cut two feathers in two down the middle to get four pieces—one of them won't be used, so you can keep the prettiest ones. I cut the end of the feather to 3/4 inches long. This gives it a better look, and it makes working on it easier.

After that, I placed them in position, 1½ to 2 inches away from the end, and started tying them onto the spots I had already marked out with a piece of gut that I cut into four pieces to get a thin but sturdy material.



THE LOST WAYS II

I tied the back side also and cut off pieces that were sticking out so that it would look better. Using a knife, I glued the feathers onto the wood for extra support.



I also cut the feathers into a slope that rose toward the end of the arrow.



THE LOST WAYS II

This is how it ended up looking in its resting position.



And when it's in use...



THE LOST WAYS II

I tried shooting with it to test it out. It was able to shoot to 82–87 feet away from me.



THE LOST WAYS II



In the end, I was impressed with the results. It did end up taking a lot of time to make, and I had to wait for a long time, but it was a really interesting project that was well worth the time I put into it. I'm even thinking

THE LOST WAYS II

about doing it again to see if I can make a different type of bow or make this design even better.

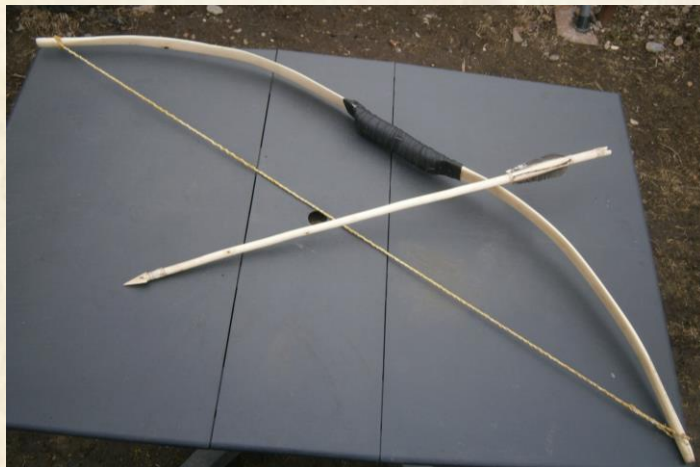

HOW TO MAKE NATTO, THE LOST SAMURAI SUPER FOOD

-By James Walton-

*“Tomorrow’s battle is won
during today’s practice.”*

– Samurai maxim

How about a dish rich in probiotics that was purportedly produced first by one of the most vicious samurai in history? You may not be familiar with the name Minamoto No Yoshiie but the Abe clan in the 2nd Century knew his name and his father’s well. This samurai later to be named God of War was a master leader and a deadly samurai. He fought in many great battles and helped solidify the prowess of the samurai in modern lore.

Even though Minamoto was a force to be reckoned with he was also a man who understood war. The story of natto begins with, strangely enough, the retreat of this great samurai.

One evening Yoshiie and his clan were boiling soybeans for the horses in large pots. The night was

THE LOST WAYS II

upon them and they would soon feed the horses before finding time to sleep themselves. No one knows at which point of his life this took place but the lore is well known. The clan was ambushed before the soybeans were finished cooking. The clan made a quick retreat but they covered the soybean pots and took them along for the ride.

Now I assume they drained the water for the sake of the hungry horses because I can only imagine the weight in those things if they were filled with boiling water. They did not open the straw bags that held the soybeans till about three days later. At this point the clan was hungry and ate the beans despite their stringy and fermented appearance. It turned out to be quite tasty and one of the samurai brought the natto to Minamoto No Yoshiie who also like the taste of it. This makes natto one of the many great foods born of war and necessity.

The snack of the samurai was left largely unchanged till about the 1920s when they figured out how to create the natto culture that would aid in the fermentation process. This allowed for larger batches to be made and made much faster.

Natto has been a part of the Japanese culture for a very long time and while this is an exceptional story to tell many believe this was an ancient food that had

been eaten even before the 2nd Century. Either way it's a powerful food packed with probiotics that should make its way into your pantry and food storage plans.

For the uninitiated natto is a food with lots of character. It is a fermented food and with that comes a distinct smell and flavor that is anything but ordinary. It's a terrific way to flavor neutral foods and is used in things like miso soup and sushi. Many have compared it to an aged cheese. I would say, if we are talking cheese, its closely akin to a brie or Camembert in the strong and musky odor. If you like it you like it if you don't you will probably hate it!

Now apart from the flavor that it imparts. An interesting survey was done in 2009 in Japan over the taste and health benefits. It found that just over 70% of the Japanese ate natto and liked it while 29% did not. Ok, so it's kind of popular, right? What was more interesting was that of the 29% that didn't like it about half of them ate it anyway for the health benefits!

The culprit behind all those great health benefits is *Bacillus subtilis* this causes the soybeans to breakdown and become something new. A serving of natto offers tremendous nutrition. It's a soybean based product so it is very high in protein in fact each serving is nearly 20% protein. Beyond the protein it's also packed with Vitamin K, Vitamin C, Iron, Manganese and Dietary

Fiber. Remember, we are talking about old soybeans here.

Because of this incredible nutritional profile natto is a powerful, yet often neglected, food storage item for preppers and survivalists. It's fermented so as long as you store it properly it will hang around for a long time. Once you open the natto you have about 2 months before it spoils. Many who enjoy this Japanese creation open the natto and keep it in their freezer until the next time they have a craving.

We are going to show you the process for creating your own natto. Yes. If you grow your own soybeans you will have the ability to create this from scratch and store what you have grown and fermented for later. Natto may be a bit foreign to many preppers and survivalists out there but that doesn't mean it's not a great option.

Mineral Rich

Essentially, natto is a dish of soaked, steamed soybeans to which a gut-friendly bacterial culture is added. Rich in calcium, magnesium, protein and potassium, the fibrous strings that are a feature of natto occur as a result of the soy protein in the beans reacting with the bacteria starter; sometimes called natto-moto.

Yeast Feast

If you have a store of dried beans to experiment with, it's worth trying – Japanese people who don't like the yeasty taste still eat natto for the numerous reported health benefits. However, millions of people across the globe find it positively ambrosial. If you like strong, fermented flavors – think aged French-style cheese - then you might well enjoy getting stuck into a bowl of natto. You don't need to stick to soybeans either; kidney beans and black beans work well too.

Although natto takes the best part of a (long) weekend to make, that's mainly just waiting time - the actual labor is pretty minimal.

You'll need:

- 2 cups soybeans (we've used black ones)
- 1/3 tsp natto-moto/starter spores (from a Japanese/Asian food store. Use the small spoon that comes with the powder – you only need a tiny amount of the spores)

The Process of Making Natto

Rinse the beans and place into a bowl deep enough to cover them. Leave for 30 minutes, stir, then remove any loose skins or debris that will have floated to the surface of the water.

THE LOST WAYS II



Drain the beans and replace with fresh water around three times the depth of the beans. Soak until the beans are around 3 times their original size (around 10 – 20 hours).

THE LOST WAYS II



Steam or boil the beans for between 1 – 3 hours, depending on how tender you like them. One hour will give you yielding but still slightly firm beans, but cook for longer if you want a softer texture.

THE LOST WAYS II



Drain the beans, cool for five minutes and stir the starter with a teaspoon of the cooking water, before adding the mixture to the beans while still warm and stirring well.

THE LOST WAYS II



THE LOST WAYS II



Now it's time to start the fermentation. Spread the beans in an even layer in an ovenproof dish and cover first with a clean muslin cloth that has been soaked in water and wrung out, and then with foil.



THE LOST WAYS II



Pre-heat the oven to 100F - 110F and place the beans in the oven to ferment, untouched for 24 hours. If you have a yoghurt maker that can be set to a constant

THE LOST WAYS II

temperature of 100F – 110F, then you can try using that, with a damp cloth lifting the lid off slightly (the bacteria needs a little air circulation).



After 24 hours, the fermentation should be complete, and you will be able to see a whitish film on the surface

THE LOST WAYS II

of the beans. You can eat the natto now, but the flavor improves with a further 24 hours aging in the fridge.



Try natto with chopped onions, peppery salad leaves, chives and hardboiled egg. It's usually eaten over rice, but some people even spread it on toast!

Once fermented and 'aged,' your natto will keep happily in the refrigerator for up to five days, or divide into portions and freeze for up to three months.

HOW TO MAKE SAUSAGES (KIELBASA) AND SMOKE THEM

-By Arminius-

*“Good luck is a residue of
preparation.”*

— Jack Youngblood

Making your own sausages is always fun and uses both your cooking and prepper skills. It takes a couple of hours to make and a couple of days to smoke, but trust me, the taste of your own homemade, smoked sausage is the best feeling. The fact that you know what’s in it and know that it doesn’t contain complicatedly named chemicals makes it taste even better.

Ingredients:

- 2 pounds of pork, with 25% fat and 75% meat. I’d recommend pork scapula or pork leg.
- Two teaspoons black pepper
- One small garlic
- Paprika (to taste)

THE LOST WAYS II

- Salt, to taste.
- (Optional) one teaspoon of cumin
- (Optional) one teaspoon of chili powder
- - 5-6 ft. of pork intestine



Getting Ready

First of all, you will need to work on the garlic. One to two hours before getting anything else ready, you need to crush the garlic and cut it into fine pieces; then place it into a cup of water. If you don't like the taste of garlic, you only need to add the water and 1/3 of the garlic to the mixture later on.

After you've done that, grab the intestine and put it into some water too; the water will help us clean it

THE LOST WAYS II

later. They usually sell them frozen, so the water helps to loosen it up too.

Grinding the Meat and Adding the Spices

First, you will need to cut the meat into slices; then use an automatic or manual grinder on the large hole settings to grind the meat down.



After you are done with that, you need to add the black pepper, the paprika, the garlic or the water it's been sitting in, the salt, the cumin, and the chili powder, if you choose to add these.

THE LOST WAYS II



Getting Messy

Now that you have added the spices, you need to mix it. I recommend mixing you're your hands as you will need to mix it thoroughly. You need to mix it for at least 15 minutes in order to get all the spices dispersed throughout the mixture.



THE LOST WAYS II

Trying Out the Sausage

After mixing, I would recommend tasting the sausage mix to make sure you get the taste you want. But frying the meat won't give you the real taste of smoked sausage.

To get that wonderful smoky taste, you need to grab some of the meat and place it in the middle of some paper. Any kind of paper will do, so just use up that old newspaper you have. Carefully wrap the paper around the meat tightly, and make sure it's sealed.



After wrapping the meat, you need to wrap it into tinfoil the same way; the tin foil is to protect it from the fire.

THE LOST WAYS II



Now that you are done wrapping it, you need to wrap it once again with paper. Make sure to use at least three to five sheets of paper to burn the paper away.



After that, you will place the wrapped meat onto some burning coal. This can be a campfire or a furnace; it

THE LOST WAYS II

doesn't matter as long as the paper can burn away evenly.

You will need to stand next to it and make sure that the paper burns down; it should take around six to eight minutes.



The end result should look like this. Taste it, and change the mixture based on your preferences. You can do this as many times as you want as long as you don't eat the whole thing.

THE LOST WAYS II

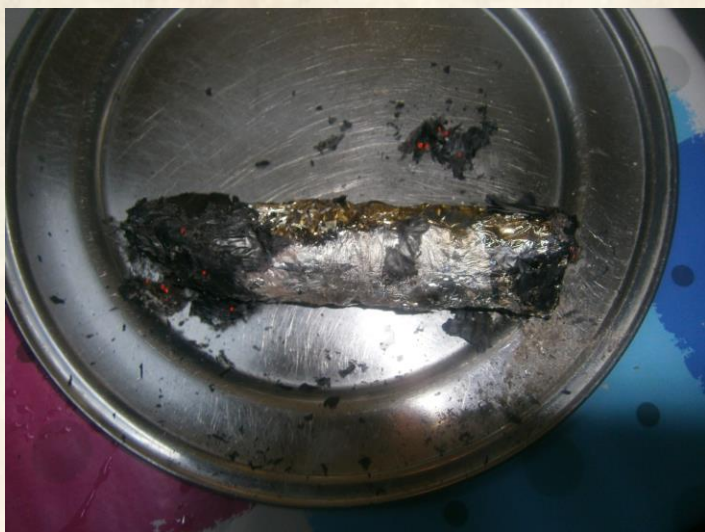

THE LOST WAYS II

Actually Making the Sausages

Now that you're sure you like the taste, you can start getting ready for the filling. First of all, you will need to clean the pork intestines, so take it out of the water you left it in, and gently let some water run through it to clean the insides too.

Now you just need to get some sort of sausage filler. If you have one at home, that's perfect. If not, you can always improvise with a bottle and a piece of wood. Just cut the bottle's bottom off and put the meat inside; then use a piece of wood or something similar to push the meat through.



THE LOST WAYS II

Now that you have your sausage filler, you need to place the intestines onto it. Just find one of the openings and push it up. Leave a little bit hanging so it doesn't run out of the intestines. Don't worry; you won't need to tie the end. The mixture is thick enough that it won't dribble out.



After you've got it on, you can start filling it up. Go slow, and make sure the sausage goes into a circle and doesn't bend anywhere. It can easily tear in this form. You also need a sausage poker or something similar to it (like a needle); this is to make sure no air gets stuck under it. Every four to eight inches, poke a hole so any air can escape. If you do see an air pocket, make sure to pop it.

THE LOST WAYS II



The finished product should look something like this.



Smoking the Sausage

When you are done with making the sausage, you can put it into your storage room if you have one; if not, then just place it into a cool place for one day. It will need to dry a little bit before you can hang it up.

After that's done, you can get the smokehouse ready for the sausages. I converted the attic of a 200-year-old house to act as a smokehouse. It originally didn't have a chimney, so all the smoke would go up to the attic. Why not use it to smoke the food?



After you have your smokehouse ready, you just need to hang up the sausage and wait for it to finish. It takes about three to five days if you smoke it all day long. Be sure to not use logs with resin on them as this has a

THE LOST WAYS II

bitter smoke. The best wood to use for smoking is oak, any fruit tree, and beech.



This is how it ended up looking after the five days were done.



THE LOST WAYS II

After this, I usually leave it to hang in my storage room for another week to dry out well. If you leave it to dry for longer (around two months), it will get a stronger, more concentrated taste and will taste fresh for up to a year. You can eat it by itself, fry it, put it into soups, or use it however you like. Try it for yourself. I promise you will love the end result.



HOW TO SMOKE BACON IN TWO DIFFERENT WAYS

-By Aaron-

“It is a truth universally acknowledged that bacon can improve any situation.”

— Jen Rasmussen

Making your own bacon is a really easy but quite time-consuming job. Almost anyone can do it with the use of some simple kitchen tools and a grill or smokehouse, which will both result in a different taste. Because of that, and because you might only have a grill or a smokehouse, I will show you the process of making bacon both ways.

Ingredients:

- 1 cup of salt
- 3 tablespoons of finely crushed garlic
- 6 cups of water
- 2 tablespoons of chili powder
- 3 tablespoons of brown sugar
- 2 tablespoons of paprika

THE LOST WAYS II

- 4 tablespoons of ground black pepper
- 2 crushed bay leaves
- 2 teaspoons of thyme
- -Pork belly (I used 5 lbs.)



THE LOST WAYS II

Preparing the Meat

The first step will be to prepare the meat, which will take a few easy steps.

First of all, remove the skin from the pork belly. Simply grab the meat and cut away the skin finely, leaving as much of the fat on the meat as possible. The sharper the knife, the better.



Getting the Curing Mix Ready

The next step will be to get the curing mix ready. Simply add the salt, black pepper, garlic, paprika, chili powder, and, finally, sugar into the water, and mix thoroughly until all the ingredients are completely combined.

THE LOST WAYS II



Curing the Bacon

After getting the meat and the mix ready, prepare to start curing it.



THE LOST WAYS II

Simply lower the meat into the mix and seal it tightly with plastic wrap. Make sure no air is under the plastic wrap, as it could ruin the whole curing process.



Be sure the meat is covered under the mix so it can soak evenly and take all the tasty ingredients into itself. I placed a glass onto it to try to push it down, but you can do it with anything as long as it gets the meat soaked.



THE LOST WAYS II

Place in the fridge and leave it in there for a week.

I would recommend turning it over daily. This will cover the meat better.



Now that the meat is ready, you need to choose an option on how you want to continue. You can use a grill or a smokehouse for smoking the meat.

Both will give you a different taste, and I believe the best option is to try both; see for yourself which one you like.

Option One: Smoking the Meat Inside a Smokehouse

Smoking your meat with a smokehouse is the slower and more time-consuming option but will take less overall effort.

THE LOST WAYS II

First of all, take the meat out of the mix and rinse it off thoroughly. Make sure no residue, black pepper, or any other ingredients from the curing are left on it.

Get your smokehouse ready, and hang the bacon up for three days, smoking it the entire time.

I used sawdust, but you can use any kind of wood except those that generate a lot of resin.

The resin will give the meat a bitter taste. The best trees for smoking are fruit trees, oak, and beech.



This is how it turned out after the smoking.



Option Two: Smoking the Meat on a Grill

This is the faster option out of the two, but it will take more concentration and effort.

First of all, take the meat out of the mix and rinse it off thoroughly. Make sure no residue, black pepper, or any other ingredients from the curing are left on it.

Right after that, you can get your fire ready, grab a container and fill it up with water, and place it in the middle of the grill. Stuff the two sides with wood in order to have two separate fires.

THE LOST WAYS II



Cover the water with tin foil; this will help with preventing the steam from escaping until we are ready to put the meat on.



THE LOST WAYS II

You can light the fire at this point. Wait for it to burn down until it's mostly just burning coal. You might need to refuel the fire with more coal, so create an extra fire or get some from your furnace.



Place the meat above the water, and let it simmer for three hours. This process will slowly boil, cook, and fry the meat all at once, giving the bacon an incredible, smoky taste that will cause your mouth to water just from smelling it.

THE LOST WAYS II



It's best to cover the fire with something. If you have a grill with a cover, you're going to have an easy time of it. I used tinfoil and a large pot.



This picture was taken at the half-hour mark. It has started frying, and the meat is slowly getting a golden-brown color.

THE LOST WAYS II



And this is the finished product.



I'd recommend leaving it in the fridge for another three to four hours to harden completely.

This is how it looked right after taking it off the grill. Don't forget that the first slice might be saltier than the rest as the salt has accumulated on the outside from the steaming.

THE LOST WAYS II



That's it. If you want to make this into a hobby, I would recommend buying one of those industrial meat slicers to get really thin slices. But apart from that, now you know how to make your own bacon.

